

J7 on is P2 force link mode (100Mbus FULL mode)
 J8 on is P2 fix mode (10Mbps mode)
 J9, J10 on is P2 use Reverse-MII mode
 J11 on is P2 use RMI mode
 J5 on is use EEPROM

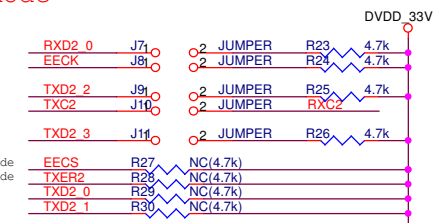

Port 0 fix FX mode
 Port 1 fix FX mode
 Port 2 link to MAC, MDIO need pull high

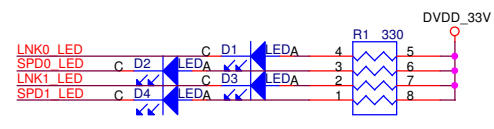
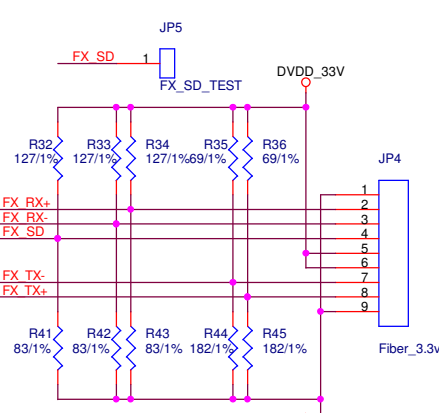
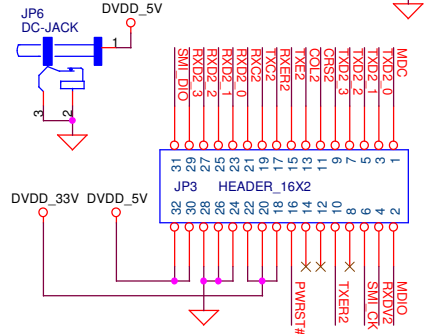
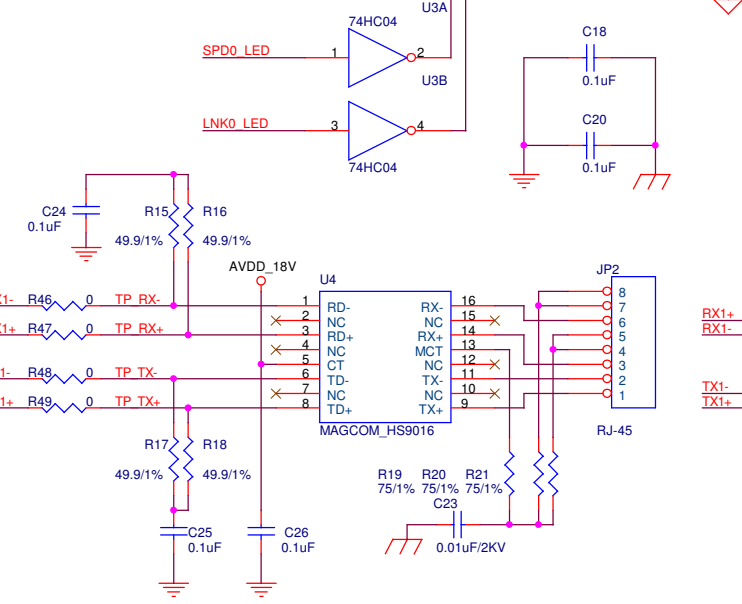
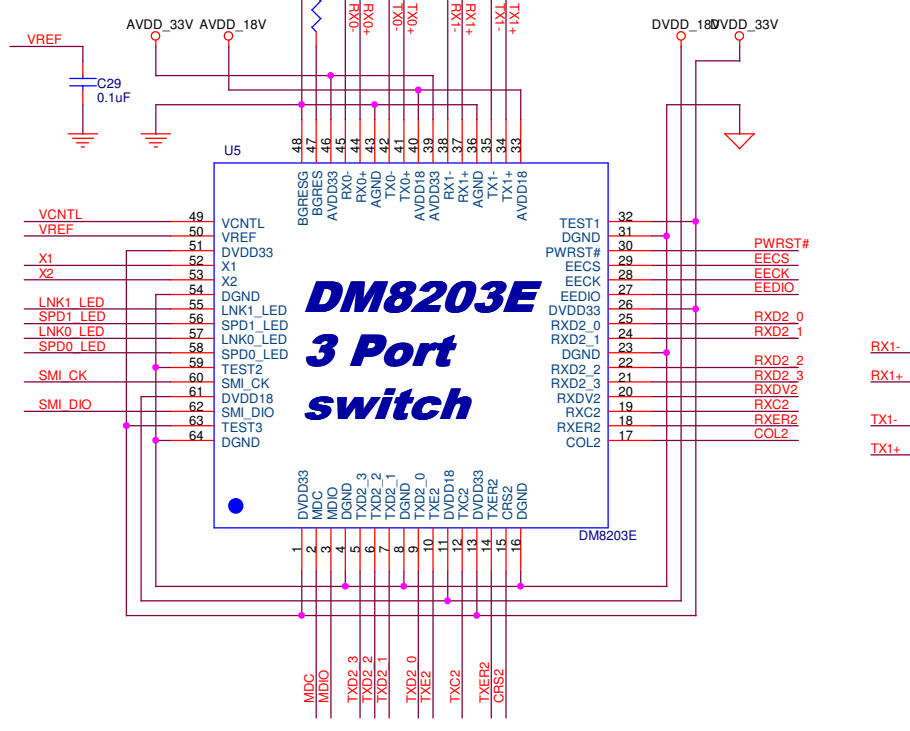
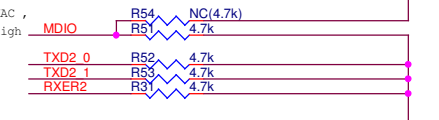
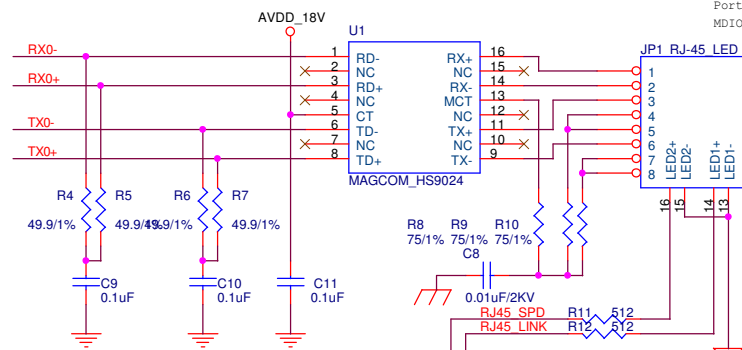
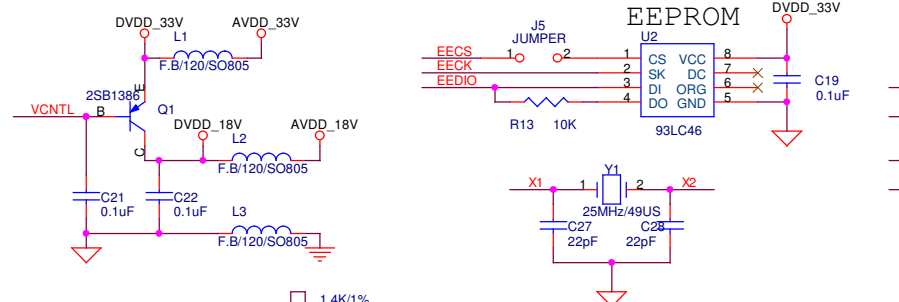

DAVICOM Semiconductor Inc.		
Title	DM8203E_EVB	
Size	Document Number	Rev
B	DM8203E_EVB_21	2.0
Date:	Thursday, August 30, 2007	Sheet 1 of 1