

# reverse MII

## MAC inside MCU & Switch DM8203

MCU MII/RMII

DM8203 reverse MII

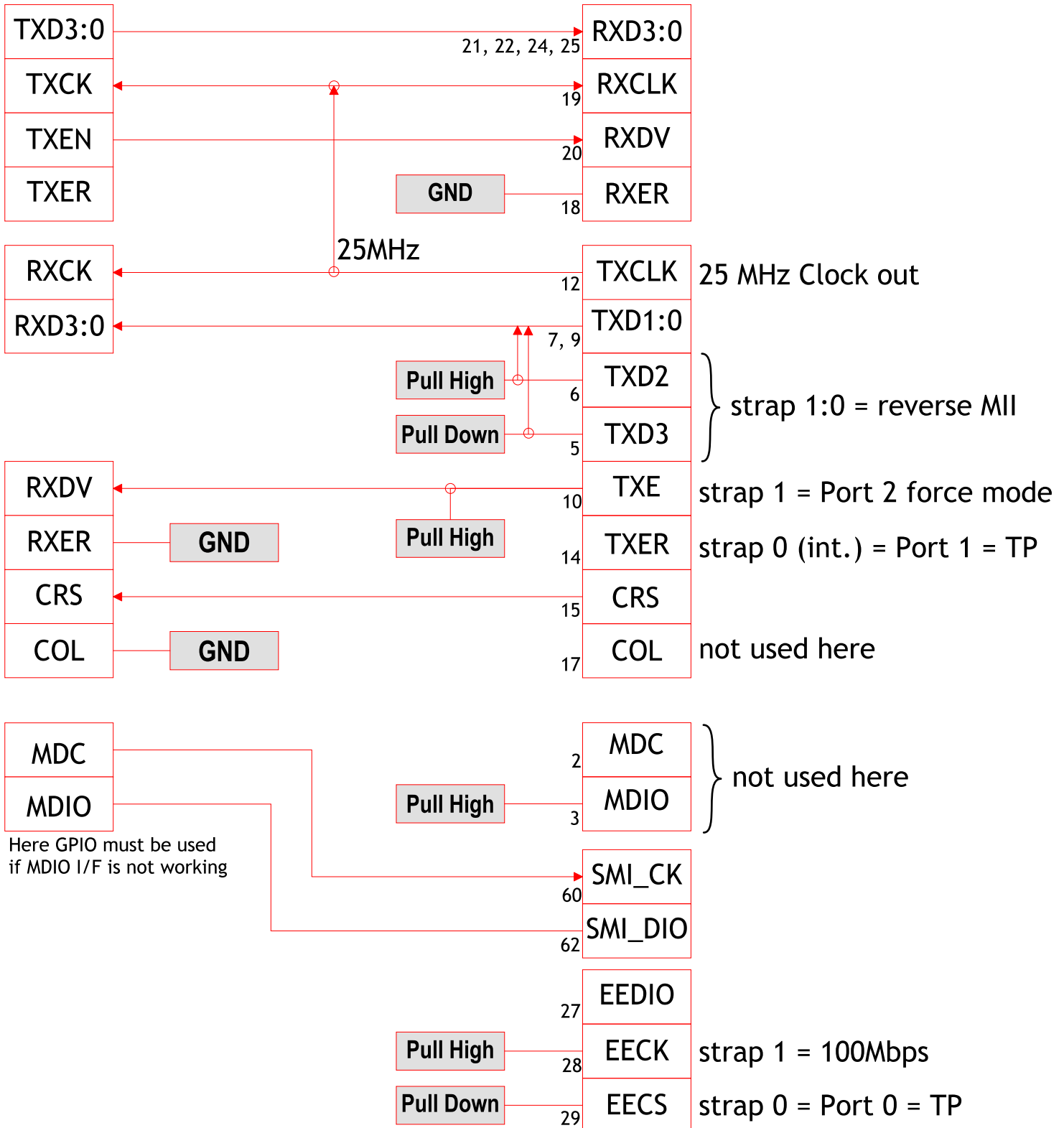

# crossed RMII

## MAC inside MCU & Switch DM8203

