

Below description depends on transformer:
 Open R17 and mount R18 for DM9010B
 Mount R17 and open R18 for DM9000
 If there is any concern please contact Davicom.

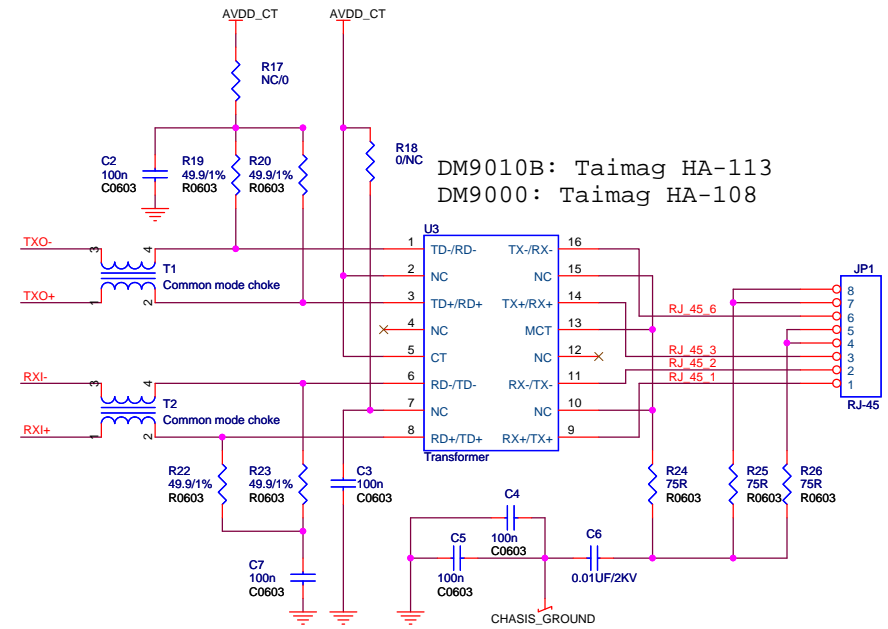

Place R19, R20, R22 and R23 close to DM9000/DM9010B

Place Y1 close to DM9000/DM9010B

Title		
DM9000+DM9010B Colayout		
Size	Document Number	Rev
A3	DM9000+DM9010B	1.1
Date:	Monday, April 26, 2010	Sheet 1 of 1