

DM9000BI 8/16-Bit Evaluation Board

User Menu

The user menu for the DM9000BI 8/16-bit evaluation board provides information for a design engineer to be able to connect the DM9000BI to any architecture. The DM9000BI 8/16-bit evaluation board is shown below.

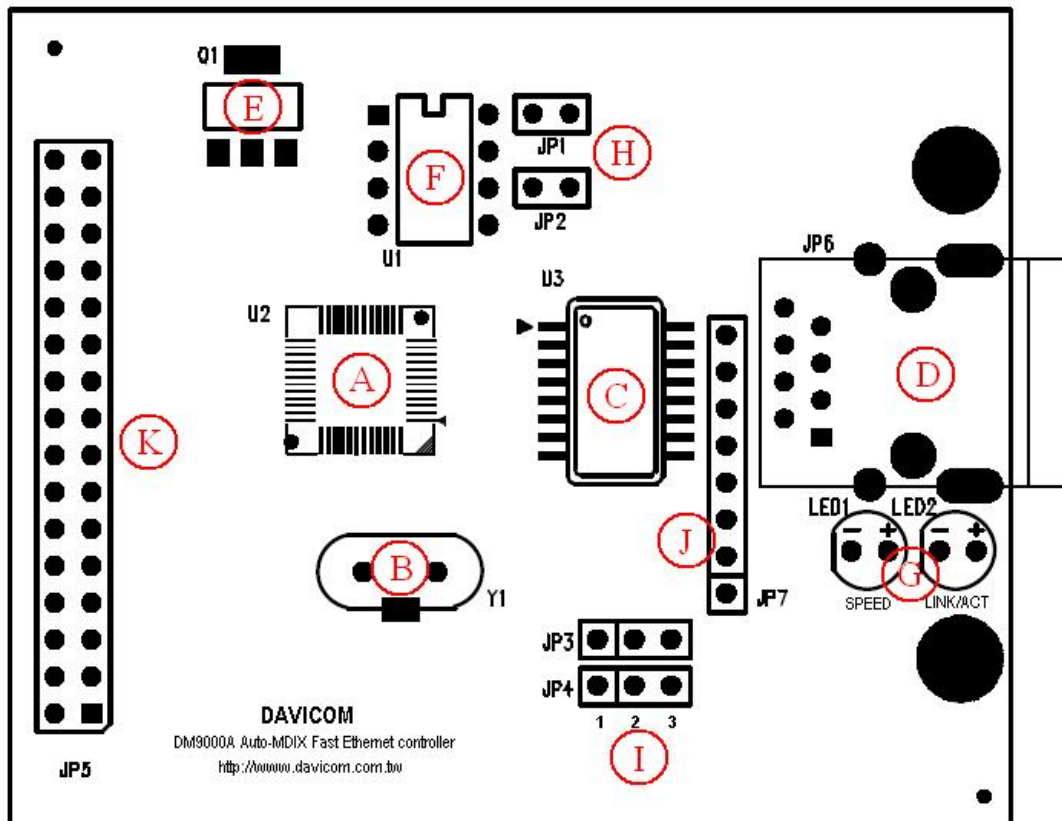

| | | | |
|---|----------------------|---|-------------------------------------|
| A | DM9000BI | G | Link status LED |
| B | 25MHz Crystal | H | 8/16bit Mode and EEPROM Setting |
| C | 10/100M Transformer | I | ISA/uP mode Setting |
| D | RJ-45 Phone Jack | J | Ethernet signals external Connector |
| E | 5V TO 3.3V Regulator | K | 8/16 bit Interface Connector |
| F | 93LC46 | | |

The detailed description of the table above is shown respectively below.

A. DM9000BI

The Davicom DM9000BI is an 8/16bits local bus supported 10/100Mbps Ethernet controller which is designed for the embedded system applications. The AUTO-MDIX switching capability to fit straight through or crossover cables is also included.

B. 25MHz Crystal

The requirement of the crystal is of 25MHz +/-30ppm.

C. 10/100M Transformer

The suitable transformers shown as follows are for the design engineers' reference.

| | |
|----------|----------------|
| GTS | FC-621SM |
| YCL | PH163539 |
| BOTHHAND | TS6121CX |
| MAGCOM | HS9016, HS9024 |

D. RJ-45

E. 5V TO 3.3V Regulator

The reference circuit of 5V to 3.3V regulator is shown below. The type of regulator Q1 is SOT-223. The design engineer should take notice of that the specification of the regulator chosen should be the same as the regulator Q1 mentioned above and the output voltage should be fixed on 3.3V.

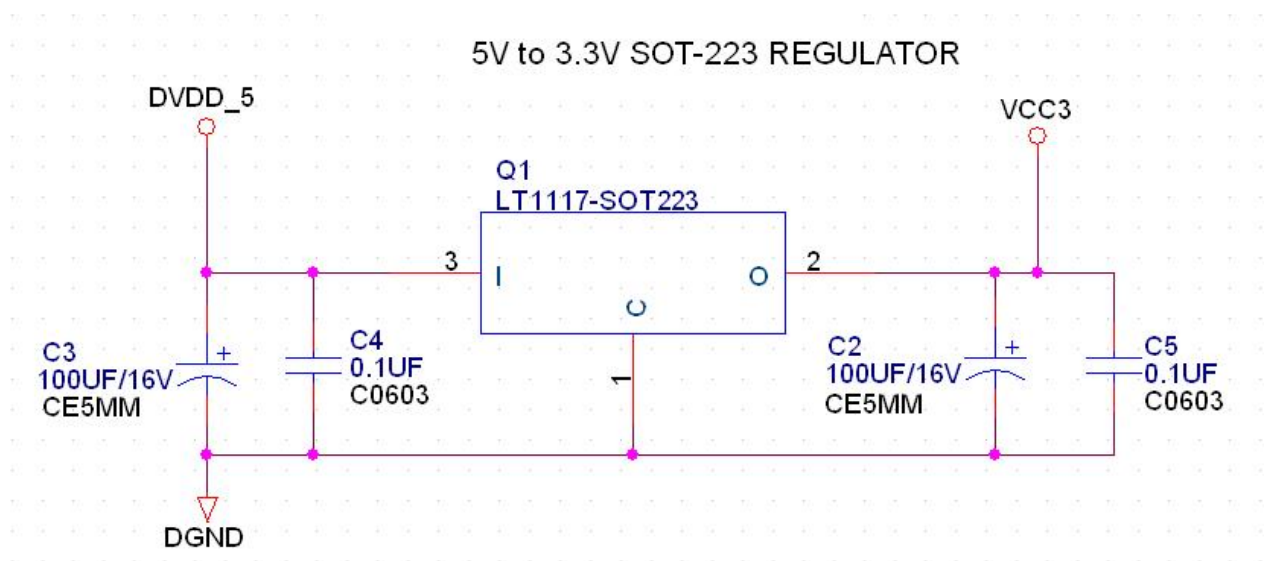

F. 93LC46

The package of 93LC46 is SOP8. In addition, the specification of the 93LC46 should be the same as the figure below.

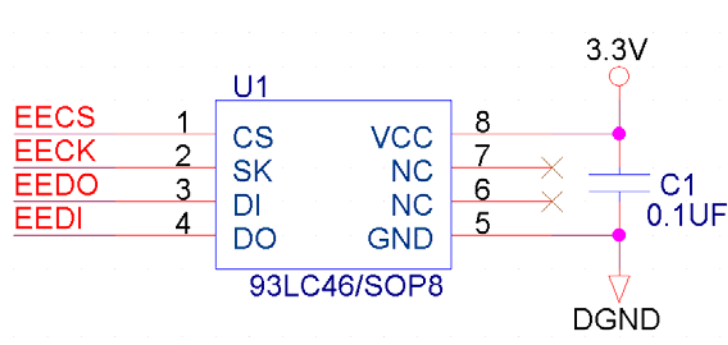
G. Link Status LEDs

1. The LINK/ACT LED is the link LED. If the LINK/ACT LED is on, it represents the link status is good. If the LINK/ACT LED is blinking, it presents that data are transmitting or receiving. If the LINK/ACT LED is off, it is probably that the link status is off or failure.
2. The SPEED LED represents the link speed is 10M or 100Mbps.
If the SPEED LED is on, the link speed is 100Mbps. If the SPEED LED is off, the link speed is 10Mbps or link fails (depend on the LINK/ACT LED).

H. 8/16bit Mode and EEPROM Setting
1. JP1:

The EECS pin is a strap pin to determine data bus width. It is pulled high for 8 bit and pulled low for 16bit.

ON: 8 bit mode.

OFF: 16 bit mode.

2. JP2:

On: EEPROM used.

OFF: EEPROM not used.

I. ISA/uP mode Setting

The LED1 pin is for SPEED LED and can be regarded as ISA IO16 function by changing EEPROM setting. In EEPROM, if the bit [15] of WORD 7 is set to 1 and bit [15:14] of WORD 3 is set to 01, the LED1 will be acted as IO16 function instead of SPEED LED.

The LED2 pin is for LINK/ACT LED and also can be regarded as IOWAIT function by changing EEPROM setting. In, EEPROM, if bit [13:12] of WORD7 is set to 01 and bit [15:14] of WORD 3 is set to 01, the LED2 will be acted as IOWAIT function instead of LINK/ACT LED.

In DM9000BI evaluation board, JP3 is used to set LED1 pin either for SPEED LED or for IO16 function. JP4 is used to set the LED2 pin either for LINK/ACT LED or for IOWAIT function. The following list is the configuration for ISA and uP mode.

1. uP mode setting:
 JP3 2-3 short, JP4 2-3 short.
2. ISA mode setting:
 JP3 1-2 short, JP4 2-3 short.
3. MDC/MDIO mode setting
 JP3 open, JP4 open.

J. Ethernet signals external Connector

The following diagram is the pin configuration of Ethernet signals external Connector.

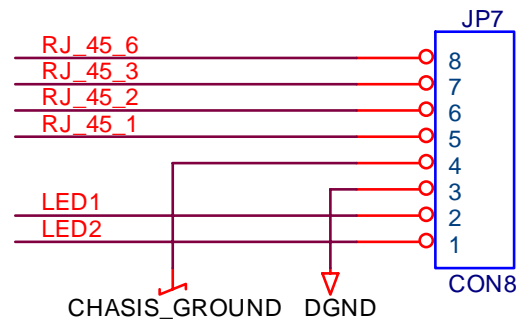

K. 8/16BIT Interface Connector

The following figure shows the pin configuration in 8/16Bit interface mode.

