

DAVICOM Semiconductor, Inc.		
Title		
USB2.0 TO ETHERNET		
Size	Document Number	Rev
A4	BLOCK	1.01
Date:	Tuesday, March 30, 2010	Sheet 1 of 4

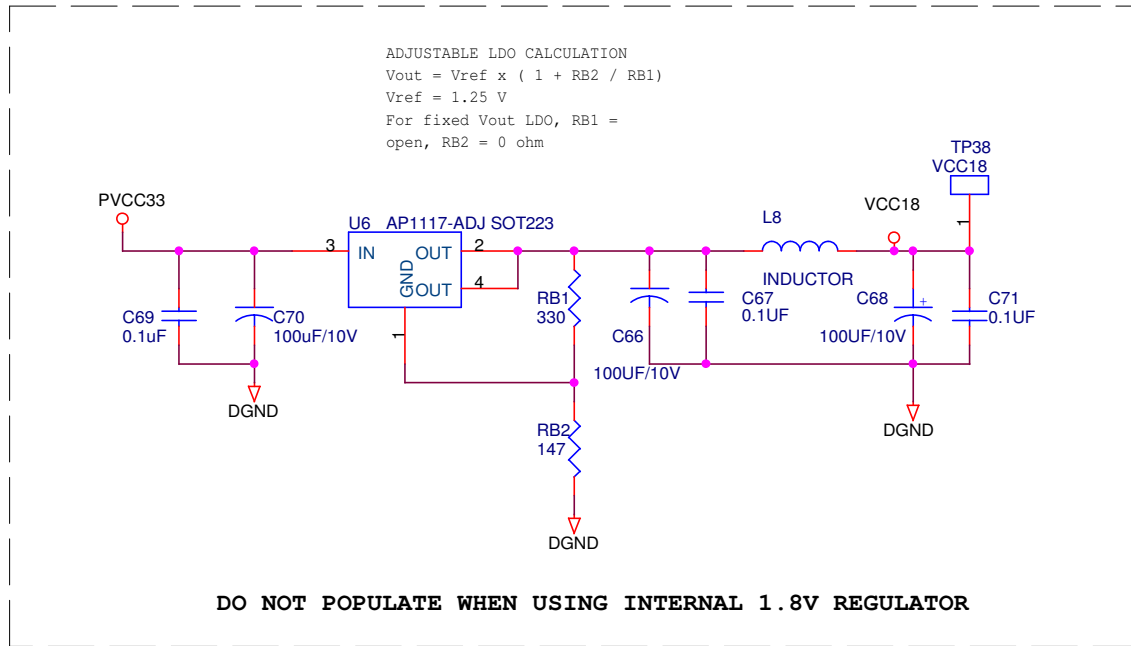
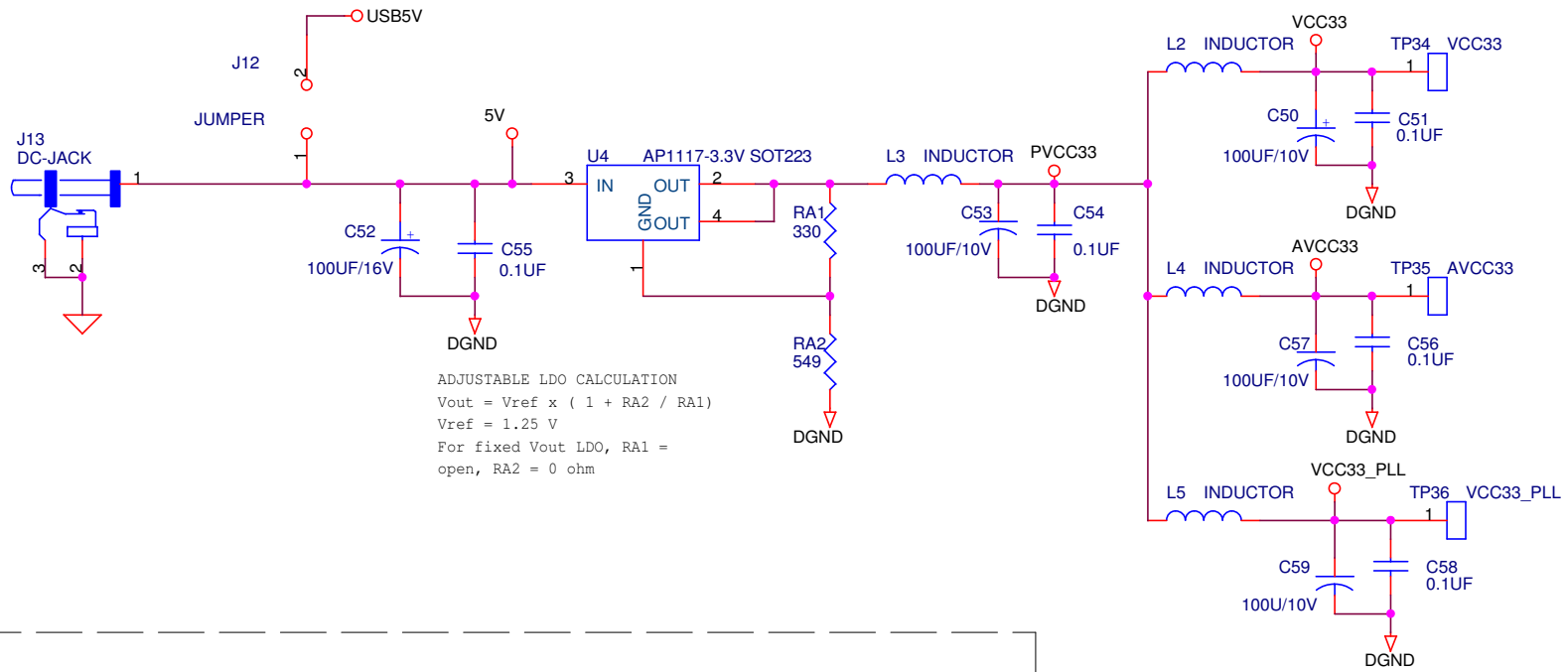

DAVICOM Semiconductor, Inc.		
Title USB2.0 TO ETHERNET		
Size A4	Document Number POWER	Rev 1.01
Date: Tuesday, March 30, 2010	Sheet 3	of 4

VER	DATE	ENGINEER	NOTE
1.0	04/28/2009	MARCO FAN	NEW CIRCUIT DM9620+DM9621
1.01	04/28/2009	WILLIE NIOU	6.8K to 6.98K UPDATE

DAVICOM Semiconductor, Inc.		
Title USB2.0 TO ETHERNET		
Size A3	Document Number HISTORY	Rev 1.01
Date: Tuesday, March 30, 2010	Sheet 4	of 4