

Features and Benefits

Triaxis™ Magnetometer (Bx, By, Bz)
On Chip Signal Processing for Robust Position Sensing
High Speed Serial Interface (SPI compatible – Full Duplex)
Enhanced Self-Diagnostics Features
5V and 3V3 Application Compatible
14 bit Output Resolution
48 bit ID Number
Single Die – SO8 Package RoHS Compliant
Dual Die (Full Redundant) – TSSOP16 Package RoHS Compliant



Applications

Absolute Contactless Position Sensor

Ordering Information¹

Part No.	Temperature Suffix	Package Code	Die Rev.	Option code	Packing ²
MLX90363	E (-40°C to 85°C)	DC [SOIC-8]	ABB	STANDARD	Reel
MLX90363	K (-40°C to 125°C)	DC [SOIC-8]	ABB	STANDARD	Reel
MLX90363	L (-40°C to 150°C) ³	DC [SOIC-8]	ABB	STANDARD	Reel
MLX90363	E (-40°C to 85°C)	GO [TSSOP-16]	ABB	STANDARD	Reel
MLX90363	K (-40°C to 125°C)	GO [TSSOP-16]	ABB	STANDARD	Reel
MLX90363	L (-40°C to 150°C) ³	GO [TSSOP-16]	ABB	STANDARD	Reel

¹ Example: MLX90363KDC-ABB-STANDARD-Reel

² For engineering purposes, a limited number of samples can also be ordered in tubes. In this case, the value “Reel” in the field “Packing” must be replaced by “Tube”.

³ MLX90363LDC-ABB-STANDARD-Reel and MLX90363LGO-ABB-STANDARD-Reel available in 2012.

1. Functional Diagram

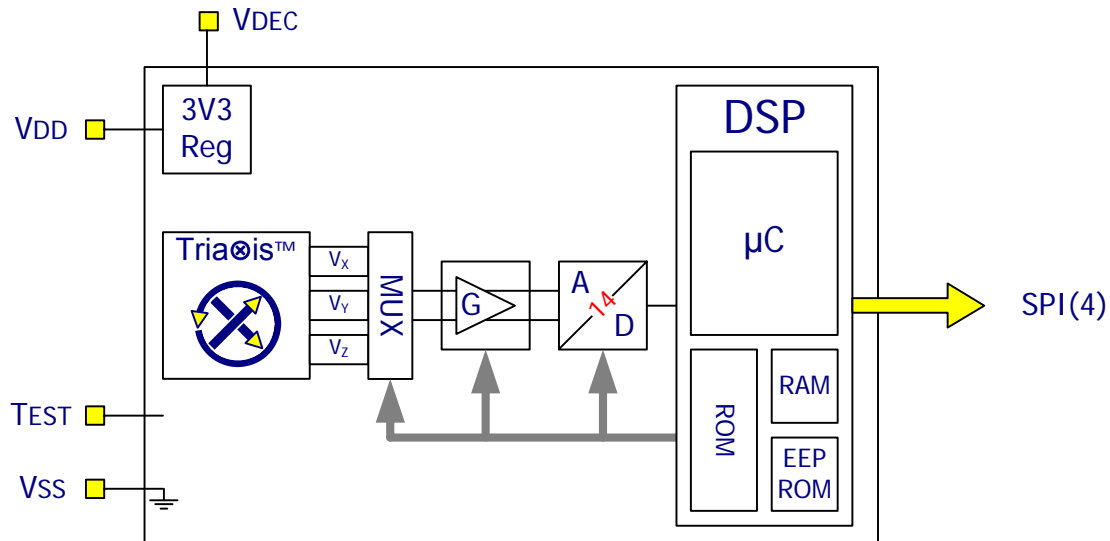

Figure 1 – Block Diagram

2. Description

The MLX90363 is a monolithic magnetic sensor IC featuring the Triaxis™ Hall technology. Conventional planar Hall technology is only sensitive to the flux density applied orthogonally to the IC surface. The Triaxis™ Hall sensor is also sensitive to the flux density applied parallel to the IC surface. This is obtained through an Integrated Magneto-Concentrator (IMC®) which is deposited on the CMOS die .

The MLX90363 is sensitive to the three (3) components of the flux density applied to the IC (i.e. Bx, By and Bz). This allows the MLX90363 to sense any magnet moving in its surrounding and decode its position through an appropriate signal processing.

Using its Serial Interface the MLX90363 can transmit a digital output (SP – 64 bits per frame).

The MLX90363 is intended for Embedded Position Sensor applications (vs. Stand-Alone “Remote” Sensor) for which the output is directly provided to a microcontroller (Master) close to the magnetometer IC MLX90363 (Slave). The SPI protocol confirms this intent.

The MLX90363 is using full duplex SPI protocol and requires therefore the separated SPI signal lines: MOSI, MISO, /SS and SLCK⁴.

⁴ The MLX90316 multiplexes the MOSI/MISO lines. The application diagrams of the MLX90363 and MLX90316 are therefore not compatible.

TABLE of CONTENTS

FEATURES AND BENEFITS	1
APPLICATIONS.....	1
ORDERING INFORMATION.....	1
1. FUNCTIONAL DIAGRAM.....	2
2. DESCRIPTION.....	2
3. GLOSSARY OF TERMS – ABBREVIATIONS – ACRONYMS	5
4. PINOUT	5
5. PIN DESCRIPTION.....	6
6. ABSOLUTE MAXIMUM RATINGS	6
7. DETAILED DESCRIPTION.....	7
8. MLX90363 ELECTRICAL SPECIFICATION.....	8
9. MLX90363 ISOLATION SPECIFICATION	8
10. MLX90363 TIMING SPECIFICATION	9
10.1. TIMING SPECIFICATION FOR 5V APPLICATION DIAGRAM.....	9
10.2. TIMING SPECIFICATION FOR 3V3 APPLICATION DIAGRAM.....	10
11. MLX90363 ACCURACY SPECIFICATION	11
12. MLX90363 MAGNETIC SPECIFICATION	13
13. MLX90363 CPU & MEMORY SPECIFICATION	13
14. MLX90363 SERIAL INTERFACE.....	14
14.1. ELECTRICAL LAYER AND TIMING SPECIFICATION	14
14.2. SERIAL PROTOCOL	16
14.3. MESSAGE GENERAL STRUCTURE	16
14.4. REGULAR MESSAGES	18
14.4.1. <i>Note for the regular message “X – Y – Z – diagnostic” (Marker = 2).....</i>	<i>18</i>
14.5. TRIGGER MODE 1	19
14.6. TRIGGER MODE 2	21
14.7. TRIGGER MODE 3	22
14.8. TRIGGER MODES TIMING SPECIFICATIONS.....	23
14.9. OPCODE TABLE	26
14.10. TIMING SPECIFICATIONS PER OPCODE, AND NEXT ALLOWED MESSAGES	26
14.11. NOP COMMAND AND NOP ANSWER	27
14.12. OSCCOUNTERSTART AND OSCCOUNTERSTOP COMMANDS	27
14.13. PROTOCOL ERRORS HANDLING.....	29
14.14. READY, ERROR AND NTT MESSAGES	30
14.15. DIAGNOSTICSDetails COMMANDS.....	31
14.16. MEMORYREAD MESSAGE.....	32
14.17. EEPROMWRITE MESSAGE	33

14.18.	REBOOT	35
14.19.	STANDBY	35
14.20.	START-UP SEQUENCE (SERIAL COMMUNICATION)	36
14.21.	ALLOWED SEQUENCES	37
15.	MLX90363 TRACEABILITY INFORMATION.....	38
16.	MLX90363 END-USER PROGRAMMABLE ITEMS.....	38
17.	MLX90363 DESCRIPTION OF END-USER PROGRAMMABLE ITEMS	39
17.1.	USER CONFIGURATION: DEVICE ORIENTATION.....	39
17.2.	USER CONFIGURATION: MAGNETIC ANGLE FORMULA	39
17.3.	USER CONFIGURATION: 3D=0 FORMULA TRIMMING PARAMETERS SMISM AND ORTH_B1B2	39
17.3.1.	<i>Magnetic Angle $\angle XY$</i>	39
17.3.2.	<i>Magnetic Angle $\angle XZ$ and $\angle YZ$</i>	40
17.4.	USER CONFIGURATION: 3D=1 FORMULA TRIMMING PARAMETERS KALPHA, KBETA, KT	40
17.5.	USER CONFIGURATION: FILTER	41
17.6.	VIRTUAL GAIN MIN AND MAX PARAMETERS	41
17.7.	HYSTERESIS FILTER	42
17.8.	EMC FILTER ON SCI PINS.....	42
17.9.	IDENTIFICATION & FREE BYTES.....	42
17.10.	LOCK.....	42
18.	MLX90363 SELF DIAGNOSTIC.....	43
19.	MLX90363 FIRMWARE FLOWCHARTS.....	44
19.1.	START-UP SEQUENCE	44
19.2.	SIGNAL PROCESSING (GETx).....	45
19.3.	FAIL-SAFE MODE	45
19.4.	AUTOMATIC GAIN CONTROL	46
20.	RECOMMENDED APPLICATION DIAGRAMS.....	47
20.1.	MLX90363 IN SOIC-8 PACKAGE AND 5V APPLICATION DIAGRAMS.....	47
20.2.	MLX90363 IN SOIC-8 PACKAGE AND 3V3 APPLICATION DIAGRAMS.....	47
20.3.	MLX90363 IN TSSOP-16 PACKAGE AND 5V APPLICATION DIAGRAMS.....	48
20.4.	MLX90363 IN TSSOP-16 PACKAGE AND 3V3 APPLICATION DIAGRAMS.....	48
21.	STANDARD INFORMATION REGARDING MANUFACTURABILITY OF MELEXIS PRODUCTS WITH DIFFERENT SOLDERING PROCESSES.....	49
22.	ESD PRECAUTIONS.....	49
23.	PACKAGE INFORMATION.....	50
23.1.	SOIC8 – PACKAGE DIMENSIONS.....	50
23.2.	SOIC8 – PINOUT AND MARKING.....	50
23.3.	SOIC8 – IMC POSITIONNING	51
23.4.	TSSOP16 – PACKAGE DIMENSIONS.....	52
23.5.	TSSOP16 – PINOUT AND MARKING.....	53
23.6.	TSSOP16 – IMC POSITIONNING	53
24.	DISCLAIMER.....	55

3. Glossary of Terms – Abbreviations – Acronyms

- Gauss (G), Tesla (T): Units for the magnetic flux density – 1 mT = 10 G
- TC: **T**emperature **C**oefficient (in ppm/Deg.C.)
- NC: **N**ot **C**onnected
- Byte: 8 bits
- Word: 16 bits (= 2 bytes)
- ADC: **A**nalog-to-**D**igital **C**onverter
- LSB: **L**east **S**ignificant **B**it
- MSB: **M**ost **S**ignificant **B**it
- DNL: **D**ifferential **N**on-**L**inearity
- INL: **I**ntegral **N**on-**L**inearity
- RISC: **R**educed **I**nstruction **S**et **C**omputer
- ASP: **A**nalog **S**ignal **P**rocessing
- DSP: **D**igital **S**ignal **P**rocessing
- ATAN: trigonometric function: arctangent (or inverse tangent)
- IMC: **I**ntegrated **M**agneto-**C**oncentrator (IMC®)
- CoRDIC: **C**oordinate **R**otation **D**igital **C**omputer (i.e. iterative rectangular-to-polar transform)
- EMC: **E**lectro-**M**agnetic **C**ompatibility
- FE: **F**alling **E**dge
- RE: **R**ising **E**dge
- MSC: **M**essage **S**equences **C**harts
- FW: **F**irmware
- HW: **H**ardware

4. Pinout

Pin #	SOIC-8	TSSOP-16
1	VDD	VDEC ₁
2	MISO	VSS ₁ (Ground ₁)
3	Test	VDD ₁
4	SCLK	MISO ₁
5	/SS	Test ₂
6	MOSI	SCLK ₂
7	VDEC	/SS ₂
8	VSS (Ground)	MOSI ₂
9		VDEC ₂
10		VSS ₂ (Ground ₂)
11		VDD ₂
12		MISO ₂
13		Test ₁
14		SCLK ₁
15		/SS ₁
16		MOSI ₁

For optimal EMC behavior, it is recommended to connect the unused pins (Test) to the Ground (see section 19).

5. Pin Description

Name	Direction	Type	Function / Description
VDD	VDD	Analog	Supply (5V and 3V3 application diagrams)
MISO	OUT	Digital	Master In Slave Out
Test	I/O	Both	Test Pin
SCLK	IN	Digital	Clock
/SS	IN	Digital	Slave Select
MOSI	IN	Digital	Master Out Slave IN
VDEC	I/O	Analog	<u>5V Application Diagrams</u> Decoupling Pin <u>3V3 Application Diagrams</u> Supply (Shorted to VDD)
Vss (Ground)	GND	Analog	Ground

6. Absolute Maximum Ratings

Parameter	Value
Supply Voltage, VDD ⁽⁵⁾	+ 18 V
Reverse VDD Voltage	- 0.3 V
Supply Voltage, VDEC	+ 3.6 V
Reverse VDEC Voltage	- 0.3 V
Positive Input Voltage	+ 11 V
Reverse Input Voltage	- 11 V
Positive Output Voltage	VDD + 0.3 V
Reverse Output Voltage	- 0.3 V
Operating Ambient Temperature Range, T _A	- 40°C ... + 150°C
Storage Temperature Range, T _S	- 40°C ... + 150°C
Magnetic Flux Density	± 700 mT

Exceeding the absolute maximum ratings may cause permanent damage. Exposure to absolute-maximum-rated conditions for extended periods may affect device reliability.

⁵ Maximum rise time: 10µs. Rise time faster than 10µs might induce an extra current consumption.

7. Detailed Description

The three components of the applied flux density are measured through the Tria \otimes is front end:

$$\begin{aligned} V_X &\propto B_X \\ V_Y &\propto B_Y \\ V_Z &\propto B_Z \end{aligned}$$

Those three (3) Hall voltages corresponding to the three (3) components of the applied flux density are provided to the ADC (Analog-to-Digital Converter). The Hall signals are processed through a fully differential analog chain featuring the classic offset cancellation technique (Hall plate 2-Phases spinning and chopper-stabilized amplifier).

The amplitude of V_Z is smaller than the two (2) components V_X and V_Y due to the fact that the magnetic gain of the IMC only affects the components parallel to the IC surface.

The conditioned analog signals are converted through a 14 bit ADC and provided to a DSP block for further processing. The DSP stage is based on a 16 bit RISC micro-controller whose primary function is the extraction of the position information (magnetic angle(s)) from the raw signals (after front-end compensation steps) through one the following operations:

$$\alpha = ATAN\left(\frac{k \cdot V_1}{V_2}\right)$$

where $V_1 = V_X$ or V_Y or V_Z , $V_2 = V_X$ or V_Y or V_Z and k (or SMISM) is a programmable factor to match the amplitude of $k V_1$ and V_2 .

$$\alpha = ATAN\left(\frac{\sqrt{(k_\alpha V_3)^2 + (k_t V_2)^2}}{V_1}\right) \text{ and } \beta = ATAN\left(\frac{\sqrt{(k_\beta V_3)^2 + (k_t V_1)^2}}{V_2}\right)$$

where $V_1 = V_X$ or V_Y or V_Z , $V_2 = V_X$ or V_Y or V_Z , $V_3 = V_X$ or V_Y or V_Z and k_α , k_β and k_t are programmable parameters.

The DSP functionality is governed by the micro-code (firmware – FW) of the micro-controller which is stored into the ROM (mask programmable). In addition to the “ATAN” (“Arctangent”) function, the FW controls the whole analog chain, the programming/calibration and also the self-diagnostic modes.

Due to the fact that the “ATAN” operation is performed on the ratios “ V_1/V_2 ”, “ V_3/V_1 ” and “ V_3/V_2 ”, the output is intrinsically self-compensated vs. flux density variations (due to airgap change, thermal or ageing effects) affecting both signals. This feature allows an improved thermal accuracy compared to a conventional linear Hall sensor.

The end-user programmable parameters are stored in EEPROM featuring a Hamming Error Correction Coding (ECC).

The programming steps do not require dedicated pins or programming tool. The operation is performed through the Master and the Serial Protocol using a dedicated and protected function⁽⁶⁾.

⁶ For debug/demo purpose, Melexis can provide the Melexis Programming Unit PTC-04 with the SPI daughterboard (PTC-04-DB-SPI) and software library (PSF – Product Specific Functions).

8. MLX90363 Electrical Specification

DC Operating Parameters at VDD = 5V (5V Application Diagram) or VDD = 3.3V (3V3 Application Diagram) and for T_A as specified by the Temperature suffix (E, K and L).

Parameter	Symbol	Test Conditions	Min	Typ	Max	Units
Nominal Supply Voltage	VDD5	5V Application Diagram	4.5	5	5.5	V
Nominal Supply Voltage	VDD33	3V3 Application Diagram	3.15	3.3	3.45	V
Supply Current ⁽⁷⁾	I _{DD}			12.5	15.5	mA
Standby Current	I _{STANDBY}			3.5	4.5	mA
Supply Current at VDD MAX	I _{DDMAX}	VDD = 18V			18	mA
POR Rising Level	POR LH	Voltage referred to VDEC	2.6	2.8	3.1	V
POR Falling Level	POR HL	Voltage referred to VDEC	2.5	2.7	2.9	V
POR Hysteresis	POR Hyst	Voltage referred to VDEC		0.1		V
MISO Switch Off Rising Level	MT8V LH	VDD level for disabling MISO ⁽⁸⁾	7.5		9.5	V
MISO Switch Off Falling Level	MT8V HL	VDD level for disabling MISO ⁽⁸⁾	6		7.5	V
MISO Switch Off Hysteresis	MT8V Hyst	VDD level for disabling MISO ⁽⁸⁾	1		2	V
Input High Voltage Level	V _{IH}		65%*VDD	-	-	V
Input Low Voltage Level	V _{IL}		-	-	35%*VDD	V
Input Hysteresis	V _{HYS}			20%*VDD		V
Input Capacitance	C _{IN}	Referred to GND		20		pF
Output High Voltage Level	V _{OH}	Current Drive I _{OH} = 0.5 mA	VDD-0.4			V
Output Low Voltage Level	V _{OL}	Current Drive I _{OH} = 0.5 mA			0.4	V
Output High Short Circuit Current	I _{shortH}	V _{OUT} forced to 0V		20	30	mA
Output Low Short Circuit Current	I _{shortL}	V _{OUT} forced to VDD		25	30	mA

9. MLX90363 Isolation Specification

Only valid for the package code GO i.e. dual die version.

Parameter	Symbol	Test Conditions	Min	Typ	Max	Units
Isolation Resistance		Between 2 dies	4			MΩ

⁷ For the dual version, the supply current is multiplied by 2

⁸ Above the MT8V threshold, no SPI communication is possible.

10. MLX90363 Timing Specification

10.1. Timing Specification for 5V Application Diagram

DC Operating Parameters at $V_{DD} = 5V$ and for T_A as specified by the Temperature suffix (E, K)⁹.

Parameter	Symbol	Test Conditions	Min	Typ	Max	Units
Main Clock Frequency	Ck		15.2		18.8	MHz
Frame Rate	FR	Trigger Mode 1 (Trg. Mod. 1), Markers 0&2, SCI 2MHz			1000	s ⁻¹
		All other modes, markers and SCI Frequencies			500	s ⁻¹
Watchdog time-out	Wd	See Section 18	15.3	18.8	20	ms
Power On to First SCI message (Start-up Time)	tStartUp	See Section 14.20	20			ms
SCI protocol: Slave-select rising- edge to falling-edge	tShort		120			us
SCI protocol: EEPROMWrite Time	teewrite	Trimmed oscillator	32			ms
Diagnostic Loop Time	tDiag	FR = 1000 s ⁻¹ , Trg.Mod.1, Mark 0&2			40	ms
		FR = 500 s ⁻¹			20	ms
		FR = 200 s ⁻¹			10	ms
Internal 1MHz signal	t1us	Ck = 19MHz		1		us
MISO Rise Time		C _L = 30pF, R _L = 10 kΩ		35	60	ns
MISO Fall Time		C _L = 30pF, R _L = 10 kΩ		35	60	ns
Magnetic Flux Density Frequency		Sinewave Flux Density ⁽¹⁰⁾				
		FR = 1000 s ⁻¹			4	Hz
		FR = 500 s ⁻¹			8	Hz
		FR = 100 s ⁻¹			18	Hz
		FR = 1000 s ⁻¹⁽¹¹⁾			28	Hz
		FR = 500 s ⁻¹⁽¹¹⁾			14	Hz
		FR = 200 s ⁻¹⁽¹¹⁾			5.6	Hz

⁹ Timing specification for "L" Temperature suffix available in 2012

¹⁰ Sensitivity monitors enable (See section 18). Beyond that frequency, the Sensitivity monitor should be disabled.

¹¹ Limitation linked to the Automatic Gain Control. Beyond that frequency, there is a reduced immunity to norm change (like vibration). See also Section 19.4.

10.2. Timing Specification for 3V3 Application Diagram

DC Operating Parameters at $V_{DD} = 3.3V$ and for T_A as specified by the Temperature suffix (E, K)¹².

Parameter	Symbol	Test Conditions	Min	Typ	Max	Units
Main Clock Frequency	Ck		13.1		18.8	MHz
Frame Rate	FR	Trigger Mode 1 (Trg. Mod. 1), Markers 0&2, SCI 2MHz			862	s ⁻¹
		All other modes, markers and SCI Frequencies			430	s ⁻¹
Watchdog time-out	Wd	See Section 18	15.3		23.2	ms
Power On to First <i>SCI</i> message (Start-up Time)	tStartUp	See Section 14.20	23.2			ms
SCI protocol: Slave-select rising- edge to falling-edge	tShort		139			us
SCI protocol: EEPROMWrite Time	teewrite	3.3V Trimmed oscillator	37			ms
Diagnostic Loop Time	tDiag	FR = 862 s ⁻¹ , Trg.Mod.1, Mark 0&2			46.4	ms
		FR = 430 s ⁻¹			23.2	ms
		FR = 215 s ⁻¹			11.6	ms
Internal 1MHz signal	t1us	Ck = 19MHz		1		us
MISO Rise Time		C _L = 30pF, R _L = 10 kΩ		35	60	ns
MISO Fall Time		C _L = 30pF, R _L = 10 kΩ		35	60	ns
Magnetic Flux Density Frequency		FR = 862 s ⁻¹⁽¹³⁾			24	Hz
		FR = 430 s ⁻¹⁽¹³⁾			12	Hz
		FR = 215 s ⁻¹⁽¹³⁾			4.8	Hz

¹² Timing specification for "L" Temperature suffix available in 2012

¹³ Limitation linked to the Automatic Gain Control. Beyond that frequency, there is a reduced immunity to norm change (like vibration). See also Section 19.4.

11. MLX90363 Accuracy Specification

DC Operating Parameters at VDD = 5V (5V Application Diagram) or VDD = 3.3V (3V3 Application Diagram) and for T_A as specified by the Temperature suffix (E, K and L).

Parameter	Symbol	Test Conditions	Min	Typ	Max	Units
ADC Resolution on the raw signals X, Y and Z	RADC			14		bit
Serial Interface Resolution	R _{SI}	On the angle value		14		bit
		On the X,Y,Z values		12		bit
Offset on the Raw Signals X, Y and Z	X0, Y0, Z0	T _A = 25°C	-30		+30	LSB ₁₄
Mismatch on the Raw Signals X, Y and Z	SMISM _{XY}	T _A = 25°C Between X and Y	-1		1	%
	SMISM _{XZ}	Between X and Z ⁽¹⁴⁾	-30		+30	%
	SMISM _{YZ}	Between Y and Z ⁽¹⁴⁾	-30		+30	%
Magnetic Angle Phase Error	ORTH _{XY}	T _A = 25°C Between X and Y	-0.3		0.3	Deg
	ORTH _{XZ}	Between X and Z ⁽¹⁵⁾	-10		10	Deg
	ORTH _{YZ}	Between Y and Z ⁽¹⁵⁾	-10		10	Deg
Intrinsic Linearity Error ⁽¹⁶⁾	Le	T _A = 25°C, Magnetic Angle ∠XY	-1		1	Deg
		Magnetic Angle ∠XZ, ∠YZ ⁽¹⁷⁾	-20		20	Deg
Supply Dependency		5V Application Diagram VDD = 4.5 ... 5.5V	-0.1		0.1	Deg
		3V3 Application Diagram VDD = 3.20 ... 3.40V				
		Temperature suffix E and K 20mT	-0.8		0.8	Deg
		50mT	-0.4		0.4	Deg
		Temperature suffix L 20mT	-1		1	Deg
		50mT	-0.6		0.6	Deg

MLX90363 Accuracy Specification continues...

¹⁴ The Mismatch between X or Y and Z can be reduced through the calibration of the SMISM (or k) factor in the end application. See section 17.3.2 for more information

¹⁵ The Magnetic Angle Phase error X or Y and Z can be reduced through the calibration of the ORTH_B1B2 factor in the end application. See section 17.3.2 for more information

¹⁶ The Intrinsic Linearity Error is a consolidation of the IC errors (offset, sensitivity mismatch, phase error) taking into account an ideal rotating field. Once associated to a practical magnetic construction and the associated mechanical and magnetic tolerances, the output linearity error increases.

¹⁷ The Intrinsic Linearity Error for Magnetic Angle ∠XZ, ∠YZ can be reduced through the programming of the SMISM (or k) factor and ORTH_B1B2. By applying the correct compensation, a non linearity error of +/-1 deg can be reached. See section 17.3.2 for more information

... MLX90363 Accuracy Specification						
Thermal Offset Drift ⁽¹⁸⁾	Temperature suffix E and K	-30		+30	LSB ₁₄	
	Temperature suffix L	-45		+45	LSB ₁₄	
Thermal Drift of Sensitivity Mismatch ⁽¹⁹⁾	XY axis, XZ axis, YZ axis Temperature suffix E and K	- 0.5		+ 0.5	%	
	Temperature suffix L	- 0.7		+ 0.7	%	
Thermal Drift of Magnetic Angle Phase Error	XY axis, XZ axis, YZ axis	0.1		0.1	Deg	
Magnetic Angle Noise ⁽²⁰⁾	Temperature suffix E and K					
	20mT, No Filter			0.20	Deg	
	50mT, No Filter			0.10	Deg	
	50mT, FILTER=1			0.07	Deg	
	Temperature suffix L					
	20mT, No Filter			0.25	Deg	
Raw signals X, Y, Z Noise ⁽²⁰⁾	50mT, No Filter			0.12	Deg	
	50mT, FILTER=1			0.08	Deg	
	Temperature suffix E and K					
20mT, No Filter			12	LSB ₁₄		
50mT, No Filter			6	LSB ₁₄		
50mT, FILTER_TYPE =1			4	LSB ₁₄		
Temperature suffix L						
20mT, No Filter			14	LSB ₁₄		
50mT, No Filter			7	LSB ₁₄		
50mT, FILTER=1			4	LSB ₁₄		

¹⁸ For instance, Thermal Offset Drift equal $\pm 30\text{LSB}_{14}$ yields to max. ± 0.32 Deg. error. This is only valid if the Virtual Gain is not fixed (See Section 17.6). See Front End Application Note for more details.

¹⁹ For instance, Thermal Drift of Sensitivity Mismatch equal $\pm 0.4\%$ yields to max. ± 0.1 Deg. error. See Front End Application Note for more details.

²⁰ Noise is defined by $\pm 3\sigma$ for 1000 successive acquisitions. The application diagram used is described in the recommended wiring (Section 20). For detailed information, refer to section Filter in application mode (Section 17.5).

12. MLX90363 Magnetic Specification

DC Operating Parameters at V_{DD} = 5V (5V Application Diagram) or V_{DD} = 3.3V (3V3 Application Diagram) and for T_A as specified by the Temperature suffix (E, K and L).

Parameter	Symbol	Test Conditions	Min	Typ	Max	Units
Magnetic Flux Density in X or Y	B _{XY} ⁽²¹⁾		20	50	70 ⁽²²⁾	mT
Magnetic Flux Density in Z	B _Z ⁽²¹⁾		24	75	126	mT
Magnet Temperature Coefficient	TC _m		-2400		0	ppm/°C
IMC Gain ⁽²³⁾	Gain _{IMC}		1.2	1.4	1.8	

13. MLX90363 CPU & Memory Specification

The digital signal processing is based on a 16 bit RISC μController featuring

- ROM & RAM
- EEPROM with hamming codes (ECC)
- Watchdog
- C Compiler

Parameter	Symbol	Test Conditions	Min	Typ	Max	Units
ROM				14		kByte
RAM				256		Byte
EEPROM				64		Byte
CPU MIPS		Ck = 15 MHz		3.5		MIPS

²¹ The condition must be fulfilled for at least one field B_x, B_y or B_z.

²² Above 70 mT, the IMC starts saturating yielding an increase of the linearity error.

²³ This is the magnetic gain linked to the Integrated Magneto Concentrator structure. It applies to B_x and B_y and not to B_z. This is the overall variation. Within one lot, the part to part variation is typically ± 10% versus the average value of the IMC gain of that lot.

14. MLX90363 Serial Interface

The MLX90363 serial interface allows a master device to operate the position sensor. The MLX90363 interface allows multi-slave applications and synchronous start of the data acquisition among the slaves. The interface offers 2 Mbps data transfer bit rate and is full duplex. The interface accepts messages of 64 bits wide only, making the interfacing robust.

In this document, the words *message*, *frame* and *packet* refer to the same concept.

14.1. Electrical Layer and Timing Specification

Message transmissions start necessarily at a falling edge on /SS and end necessarily at a rising edge on the /SS signal. This defines a message. The serial interface counts the number of transmitted bits and declares the incoming message invalid when the bit count differs from 64. The master must therefore ensure the flow described below:

1. Set pin /SS Low
2. Send and receive 8 bytes or four (4x) 16 bit words
3. Set pin /SS High

The *MISO* and *MOSI* signals change on *SCLK* rising edge and are captured on *SCLK* falling edge. The most-significant-bit of the transmitted byte or word comes first ⁽²⁴⁾.

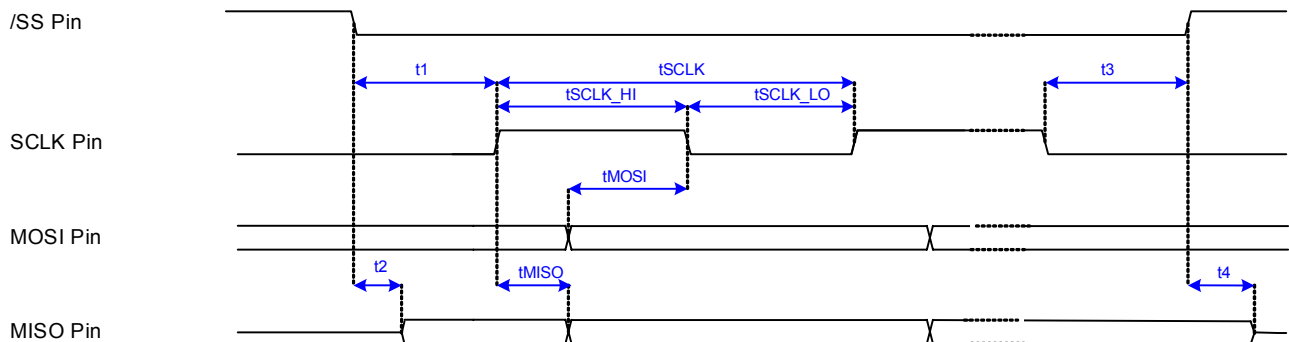

Figure 2 – Serial Interface Timing Diagram

The interface is sensitive, in Trigger mode 2 (see section 14.6), to *Sync* pulses. A *Sync* pulse is negative pulse on /SS, while *SCLK* is kept quiet.

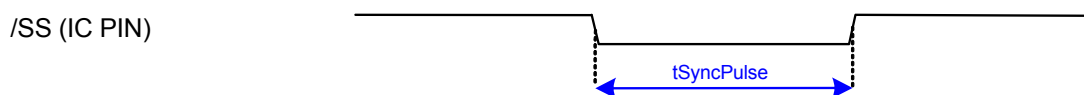

Figure 3 – Sync Pulse Timing Diagram

²⁴ For instance, for master compatible w/ the Motorola SPI protocol, the configuration bits must be *CPHA*=1, *CPOL*=0, *LSBFE*=0.

Parameter	Symbol	Test Conditions	Min	Typ	Max	Units
Clock Period	tSCLK	EE_PINFILTER = 1	450	500		ns
		EE_PINFILTER = 2	900	1000		ns
		EE_PINFILTER = 3	1800	2000		ns
Clock Low Level	tSCLK_HI	EE_PINFILTER = 1	225			ns
		EE_PINFILTER = 2	450			ns
		EE_PINFILTER = 3	900			ns
Clock High Level	tSCLK_LO	EE_PINFILTER = 1	225			ns
		EE_PINFILTER = 2	450			ns
		EE_PINFILTER = 3	900			ns
Clock to Data Delay	tMISO	EE_PINFILTER = 1 , Cload = 30pF			210	ns
		EE_PINFILTER = 2 , Cload = 30pF			300	ns
		EE_PINFILTER = 3 , Cload = 30pF			510	ns
Data Capture Setup Time	tMOSI		30			ns
/SS FE to SCLK RE	t1	EE_PINFILTER = 1	225			ns
		EE_PINFILTER = 2	450			ns
		EE_PINFILTER = 3	900			ns
/SS FE to MISO Low Impedance	t2	EE_PINFILTER = 1		90	120	ns
		EE_PINFILTER = 2		180	210	ns
		EE_PINFILTER = 3		370	420	ns
SCLK FE to /SS RE	t3		225			ns
/SS RE to MISO High Impedance	t4	EE_PINFILTER = 1		90	120	ns
		EE_PINFILTER = 2		180	210	ns
		EE_PINFILTER = 3		370	420	ns
Sync Pulse Duration	tSyncPulse	EE_PINFILTER = 1	520		10000	ns
		EE_PINFILTER = 2	610		10000	ns
		EE_PINFILTER = 3	820		10000	ns

Table 1 - Serial Interface Timing Specifications

Melexis recommends using the multi-slave application diagram as shown on the right.

The *SCLK*, *MISO* and *MOSI* wires interconnect the slaves with the master. A slave is selected by its dedicated */SS* input. A slave *MISO* output is in high-impedance state when the slave is not selected.

Slaves can be triggered synchronously by sending *Sync* pulses on the different */SS*. The pulses must not overlap to avoid electrical short-circuits on the *MISO* bus.

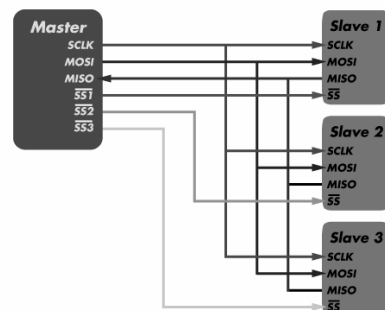

14.2. Serial Protocol

The serial protocol of MLX90363 allows the SPI master device to request the following information:

- Position (magnetic angle Alpha)
- Raw field components (X,Y and Z)
- Self-Diagnostic data

It allows customizing the calibration of the sensor, when needed, at the end-of-line, through EEPROM programming.

The serial protocol offers a transfer rate of 1000 messages/sec. A regular message holds position and diagnostic information. The data acquisition start and processing is fully under the control of the SPI master. The user configuration bits, stored in EEPROM, are programmable with this protocol.

Data integrity is guaranteed in both directions by an 8 bit CRC covering the content of the incoming and outgoing messages. In a dual sensors application, a *Sync* pulse allows a synchronous start of the raw signals acquisition.

14.3. Message General Structure

A message has a unique *Opcode*. The general structure of a message consists of 8 bytes (byte #0, transmitted first, to byte #7 transmitted last).

Byte #7 (the last byte transmitted) holds an 8 bit CRC. The byte #6 holds a *Marker* plus either an *Opcode* or a *rolling counter*.

#	7	6	5	4	3	2	1	0	#	7	6	5	4	3	2	1	0
1	(4)							(3)	0	(2)							(1)
3									2								(5)
5									4								
7	CRC							6	Marker	Opcode or Roll Counter							

Table 2 – General Structure of a message and bit naming convention

- (1) This bit is named Byte0[0] (2) This bit is named Byte0[7]
 (3) This bit is named Byte1[0] (4) This bit is named Byte1[7]
 (5) This bit is named Byte2[0]

A blank cell refers necessarily to a bit 0.

In a byte, the most-significant-bit is transmitted first (for instance, Byte0[7] is transmitted first, Byte0[0] transmitted last).

Parameter *CRC*[7:0] is Byte7[7:0], Parameter *Marker*[1:0] is Byte6[7:6],
 Parameter *Opcode*[5:0] (or *Roll Counter*[5:0]) is Byte6[5:0]

CRCs are encoded and decoded according the following algorithm (language-C):

```

crc = 0xFF;
crc = cba_256_TAB[ Byte0 ^ crc ];
crc = cba_256_TAB[ Byte1 ^ crc ];
crc = cba_256_TAB[ Byte2 ^ crc ];
crc = cba_256_TAB[ Byte3 ^ crc ];
crc = cba_256_TAB[ Byte4 ^ crc ];
crc = cba_256_TAB[ Byte5 ^ crc ];
crc = cba_256_TAB[ Byte6 ^ crc ];
crc = ~crc;
  
```

The Table 3 corresponds to the CRC-8 polynomial “0xC2”.

cba_256_TAB	1	2	3	4	5	6	7	8
1	0x00	0x2f	0x5e	0x71	0xbc	0x93	0xe2	0xcd
2	0x57	0x78	0x09	0x26	0xeb	0xc4	0xb5	0x9a
3	0xae	0x81	0xf0	0xdf	0x12	0x3d	0x4c	0x63
4	0xf9	0xd6	0xa7	0x88	0x45	0x6a	0x1b	0x34
5	0x73	0x5c	0x2d	0x02	0xcf	0xe0	0x91	0xbe
6	0x24	0x0b	0x7a	0x55	0x98	0xb7	0xc6	0xe9
7	0xdd	0xf2	0x83	0xac	0x61	0x4e	0x3f	0x10
8	0x8a	0xa5	0xd4	0xfb	0x36	0x19	0x68	0x47
9	0xe6	0xc9	0xb8	0x97	0x5a	0x75	0x04	0x2b
10	0xb1	0x9e	0xef	0xc0	0x0d	0x22	0x53	0x7c
11	0x48	0x67	0x16	0x39	0xf4	0xdb	0xaa	0x85
12	0x1f	0x30	0x41	0x6e	0xa3	0x8c	0xfd	0xd2
13	0x95	0xba	0xcb	0xe4	0x29	0x06	0x77	0x58
14	0xc2	0xed	0x9c	0xb3	0x7e	0x51	0x20	0x0f
15	0x3b	0x14	0x65	0x4a	0x87	0xa8	0xd9	0xf6
16	0x6c	0x43	0x32	0x1d	0xd0	0xff	0x8e	0xa1
17	0xe3	0xcc	0xbd	0x92	0x5f	0x70	0x01	0x2e
18	0xb4	0x9b	0xea	0xc5	0x08	0x27	0x56	0x79
19	0x4d	0x62	0x13	0x3c	0xf1	0xde	0xaf	0x80
20	0x1a	0x35	0x44	0x6b	0xa6	0x89	0xf8	0xd7
21	0x90	0xbf	0xce	0xe1	0x2c	0x03	0x72	0x5d
22	0xc7	0xe8	0x99	0xb6	0x7b	0x54	0x25	0x0a
23	0x3e	0x11	0x60	0x4f	0x82	0xad	0xdc	0xf3
24	0x69	0x46	0x37	0x18	0xd5	0xfa	0x8b	0xa4
25	0x05	0x2a	0x5b	0x74	0xb9	0x96	0xe7	0xc8
26	0x52	0x7d	0x0c	0x23	0xee	0xc1	0xb0	0x9f
27	0xab	0x84	0xf5	0xda	0x17	0x38	0x49	0x66
28	0xfc	0xd3	0xa2	0x8d	0x40	0x6f	0x1e	0x31
29	0x76	0x59	0x28	0x07	0xca	0xe5	0x94	0xbb
30	0x21	0x0e	0x7f	0x50	0x9d	0xb2	0xc3	0xec
31	0xd8	0xf7	0x86	0xa9	0x64	0x4b	0x3a	0x15
32	0x8f	0xa0	0xd1	0xfe	0x33	0x1c	0x6d	0x42

Table 3 – cba_256_TAB Look-up table Polynomial “C2”

#	7	6	5	4	3	2	1	0	#	7	6	5	4	3	2	1	0
1	0xFF								0	0xC1							
3	0xFF								2	0x16							
5	0xFF								4	0xD4							
7	0x23								6	0x86							

Table 4 – Example of valid CRC

14.4. Regular Messages

The MLX90363 offers three types of regular messages:

- “α” – diagnostic
- “α – β” – diagnostic
- X – Y – Z – diagnostic

#	7	6	5	4	3	2	1	0	#	7	6	5	4	3	2	1	0
1	E1	E0	ALPHA [13:8]						0	ALPHA [7:0]							
3	0						2	0									
5	0						4	VG[7:0]									
7	CRC						6	0	0	ROLL							

Table 5 – “α” message

#	7	6	5	4	3	2	1	0	#	7	6	5	4	3	2	1	0
1	E1	E0	ALPHA [13:8]						0	ALPHA [7:0]							
3			BETA [13:8]						2	BETA [7:0]							
5	0						4	VG[7:0]									
7	CRC						6	0	1	ROLL							

Table 6 – “α – β” message

#	7	6	5	4	3	2	1	0	#	7	6	5	4	3	2	1	0
1	E1	E0	X COMPONENT [13:8]						0	X COMPONENT [7:0]							
3			Y COMPONENT [13:8]						2	Y COMPONENT [7:0]							
5			Z COMPONENT [13:8]						4	Z COMPONENT [7:0]							
7	CRC						6	1	0	ROLL							

Table 7 – “X – Y – Z” message

The bits byte6[7] and byte6[6] are markers. They allow the master to recognize the type of regular message (00b, 01b, 10b). The marker is present in all messages (incoming and outgoing). The marker of any message which is not a regular message is equal to 11b.

The bits E1 and E0 report the status of the diagnostics (4 possibilities) as described in the Table 8 – See section 18 for more details.

E1	E0	Description
0	0	First Diagnostics Sequence Not Yet Finished
0	1	Diagnostic Fail
1	0	Diagnostic Pass (Previous cycle)
1	1	Diagnostic Pass – New Cycle Completed

Table 8 - Diagnostics Status Bits

14.4.1. Note for the regular message “X – Y – Z – diagnostic” (Marker = 2)

In the case of marker = 2, the X,Y,Z components are given after offset compensation and filtering (see signal processing in section 19.2). These components are gain dependent (see also section 17.6). The sensitivity in the X and Y direction is always higher than the Z direction by the IMC Gain factor (see parameter GainIMC in section 12). Melexis therefore recommends multiplying the Z component by the GainIMC factor inside the master in order to use the MLX90363 as a 3D magnetometer.

14.5. Trigger Mode 1

The master sends a GET1 command to initiate the magnetic field acquisition and post-processing. It waits t_{SSREFE} , issues the next GET1 and receives at the same time the regular message resulting from the previous GET.

The field sensing, acquisition and post-processing is starting on /SS rising edge events.

Although GET1 commands are preferably followed by another GET1 command or a NOP command, any other commands are accepted by the slave.

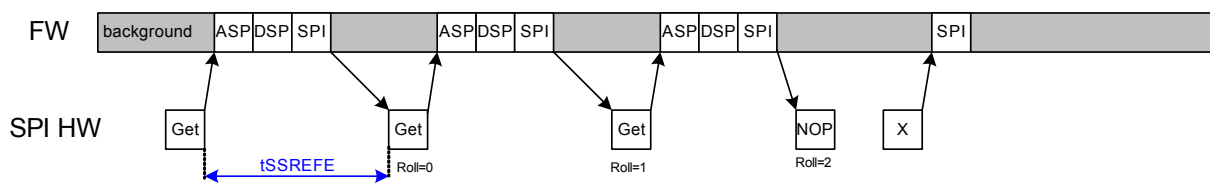

Figure 4 – Trigger mode 1

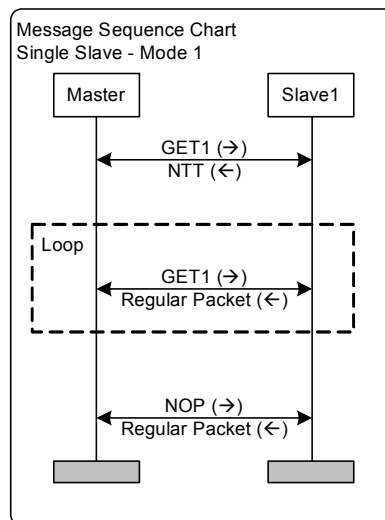

Figure 5 – Trigger Mode 1 Message Sequence Chart

#	7	6	5	4	3	2	1	0	#	7	6	5	4	3	2	1	0
1								RST	0								
3	Time-Out							2	Value								
5									4								
7	CRC							6	Marker	0	1	0	0	1	1		

Table 9 – GET1 MOSI Message (Opcode = 19)

Note: The NOP message is described at section “14.11”

- The parameter *Marker* defines the regular data packet type expected by the master:

Marker = 0 refers to frame type “ALPHA + Diagnostic”.

Marker = 1 refers to frame type “ALPHA + BETA + Diagnostic”.

Marker = 2 refers to frame type “Components X + Y + Z +Diagnostic”.

- The parameter *Rst* (Byte1[0]) when set, resets the rolling counter attached to the regular data packets.
- The parameter *TimeOutValue* tells the maximum life time of the Regular Data Message. The time step is t1us (See table in Section 10), the maximum time-out is 65535 * t1us. The time-out timer starts when the message is ready, and stops on the SS rising edge of the next message.

On time-out occurrence, there are two possible scenarios:

Scenario 1. SS is high, there is no message exchange. In this case, a NTT message replaces the regular message in the SCI buffer.

Scenario 2. SS is low, the regular packet is being sent out. In this case, the timeout violation is reported on the next message, this later being an NTT message.

14.6. Trigger Mode 2

The Trigger Mode 1 works without Sync pulses, as the GET1 command plays the role of a sync pulse. When a delay between the regular message readback and the start of acquisition is needed, or when two or more slaves should be triggered synchronously, the use of a sync pulse is required, and this is the meaning of the Trigger Mode 2.

Principle: The master first enables the trigger mode 2 by issuing a GET2 command.

The master then sends a Sync Pulse, at the appropriate time, to initiate the magnetic field acquisition and post-processing.

Finally the master reads the response message with a NOP or a GET2. The GET2 command re-initiates a sync pulse triggered acquisition, whereas the NOP command would just allow the master to receive the latest packet.

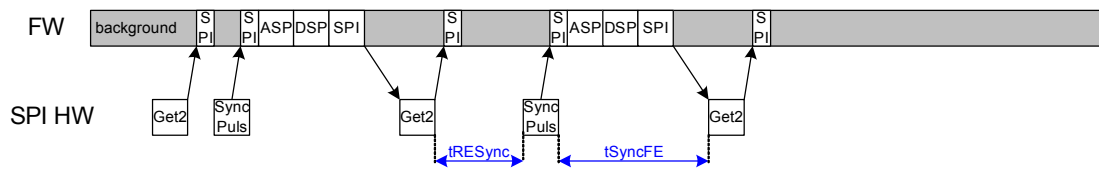

Figure 6 – Trigger Mode 2 – Single Slave Approach

A timing constraint between GET2 and the sync pulse (t_{RESync}) should be met.

When this timing is smaller than the constraint, the sync pulse might not be taken in account, causing the next GET2 to return a NTT packet.

GET1 and GET2/SyncPulse can be interlaced.

Multi-slave approach: The way of working described below fits the multi-slave applications where synchronous acquisitions are important. GET2 commands are sent one after the other to the slaves. Then the Sync Pulses are sent almost synchronously (very shortly one after the other).

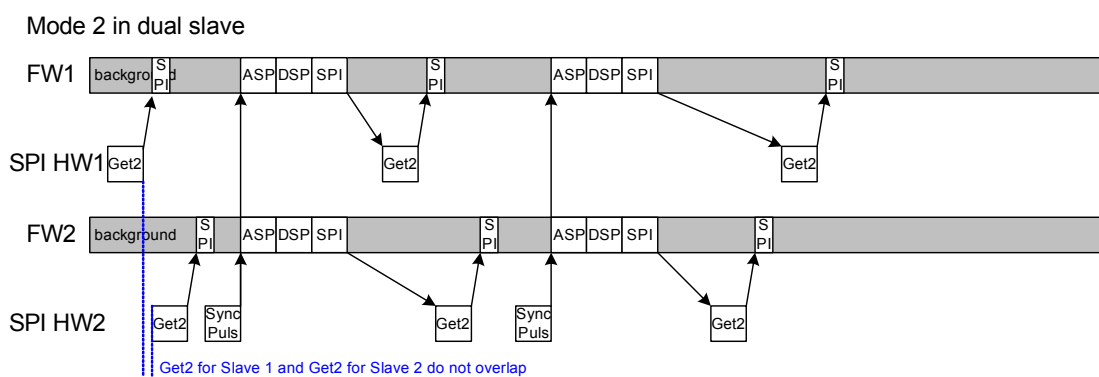

Figure 7 – Trigger mode 2 - Multi-slave approach, example for two slaves

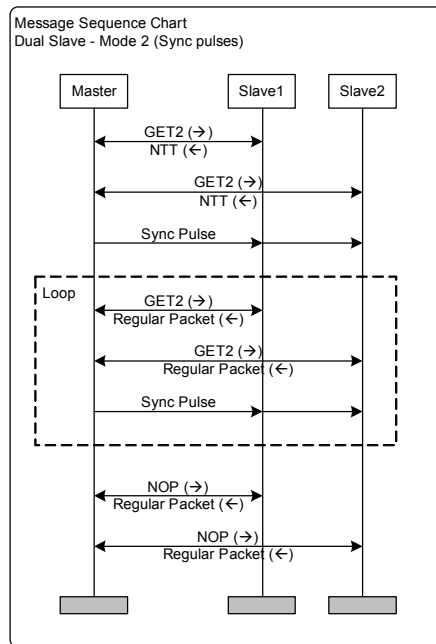

Figure 8 – Trigger mode 2 Message Sequence Chart

#	7	6	5	4	3	2	1	0	#	7	6	5	4	3	2	1	0	
1								RST	0									
3	Time - Out							2	Value									
5									4									
7	CRC							6	Marker	0	1	0	1	0	0			

Table 10 – GET2 MOSI Message (Opcode = 20)

Parameter definition: See GET1 (Section 14.5).

14.7. Trigger Mode 3

Principle: The acquisition sequences are triggered by a GET message, but unlike the Mode 1, the resulting data (position ...) is buffered. The slave-out messages contain the buffered data of the previous GET message, and not the newly computed values corresponding to the current GET slave-in request. The buffering releases constraints on the SCI clock frequency (*SCLK*). The Mode 3 offers frame rates as high as Mode 1, if not higher, with slower *SCLK* frequencies. When the clock frequency is limited (400 kbps or less), and when it matters to reach a certain frame rate, Mode 3 is preferred over Mode 1. In any other cases, for instance when the shortest response time represents the main design criteria, Mode 1 is preferred.

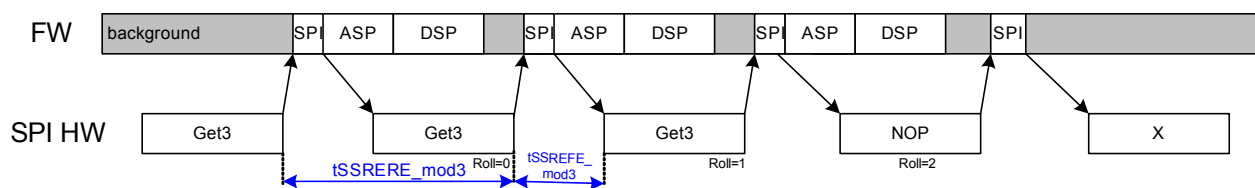

Figure 9 – Trigger mode 3

GET3 sequences must end with a NOP.

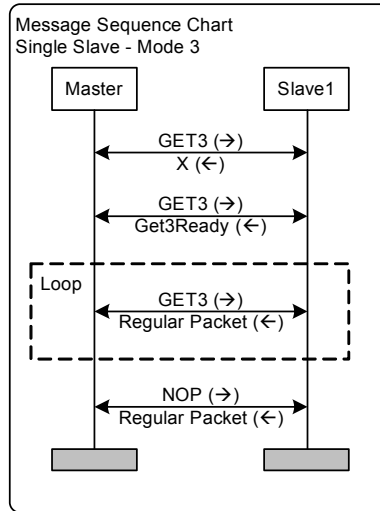

Figure 10 – Trigger mode 3 Message Sequence Chart

#	7	6	5	4	3	2	1	0	#	7	6	5	4	3	2	1	0	
1								RST	0									
3	Time-Out								2	Value								
5									4									
7	CRC								6	Marker	0	1	0	1	0	1		

Table 11 – GET3 MOSI Message (Opcode = 21)

Parameter definition: See GET1 (Section 14.5)

#	7	6	5	4	3	2	1	0	#	7	6	5	4	3	2	1	0	
1									0									
3									2									
5									4									
7	CRC								6	1	1	1	0	1	1	0	1	

Table 12 – Get3Ready Slave-Out Message (Opcode = 45)

14.8. Trigger Modes Timing Specifications

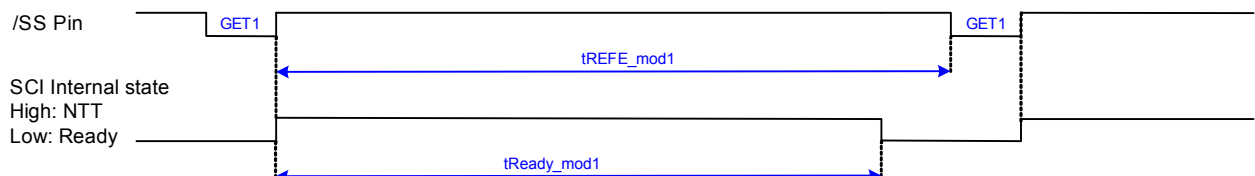

Figure 11 – Trigger mode 1 timing diagram

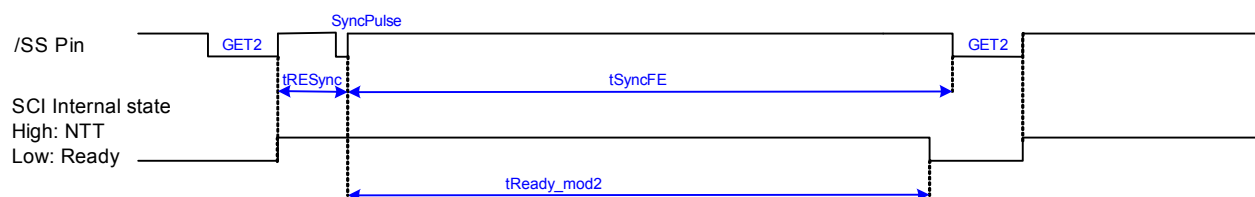

Figure 12 – Trigger mode 2 timing diagram

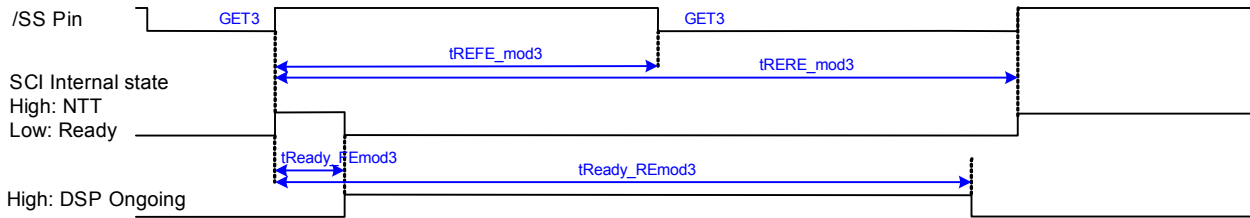

Figure 13 – Trigger mode 3 timing diagram

5V Application Diagram

Items	Definition	Marker	Min	Typ	Max	Unit
<i>tREFE_mod1</i>	Get1 SS Rising Edge to next Get1 SS Falling Edge	0	920			µs
		1	1050			µs
		2	920			µs
<i>tReady_mod1</i>	Get1 SSRE to SO Answer ReadyToTransmit	0			920	µs
		1			1050	µs
		2			920	µs

Table 13 – Trigger Modes Timing Specification (Mode 1, VDD=5V)

Items	Definition	Marker	Min	Typ	Max	Unit
<i>tSyncFE</i>	Sync Pulse (RE) to Get2 Falling Edge	0	874			µs
		1	1004			µs
		2	874			µs
<i>tReady_mod2</i>	Sync Pulse (RE) to SO Answer ReadyToTransmit	0			874	µs
		1			1004	µs
		2			874	µs
<i>tRESync</i>	Get2 SS Rising Edge to Sync Pulse (RE)		80			µs

Table 14 – Trigger Modes Timing Specification (Mode 2, VDD=5V)

Items	Definition	Marker	Min	Typ	Max	Unit
<i>tRERE_mod3</i>	Get3 SS RE to RE	0	950			µs
		1	1080			µs
		2	950			µs
<i>tReadyRE_mod3</i>	Get3 SS RE to DSP Completion	0			950	µs
		1			1080	µs
		2			950	µs
<i>tREFE_mod3</i>	Get3 SS Rising to Falling		90			µs
<i>tReadyFE_mod3</i>	Get3 SS RE to SO Answer ReadyToTransmit				90	µs

Table 15 – Trigger Modes Timing Specification (Mode 3, VDD=5V)

3V3 Application Diagram

Items	Definition	Marker	Min	Typ	Max	Unit
<i>tREFE_mod1</i>	Get1 SS Rising Edge to next Get1 SS Falling Edge	0	1067			µs
		1	1218			µs
		2	1067			µs
<i>tReady_mod1</i>	Get1 SSRE to SO Answer ReadyToTransmit	0			1067	µs
		1			1218	µs
		2			1067	µs

Table 16 – Trigger Modes Timing Specification (Mode 1, VDD = 3.3V)

Items	Definition	Marker	Min	Typ	Max	Unit
<i>tSyncFE</i>	Sync Pulse (RE) to Get2 Falling Edge	0	1014			µs
		1	1165			µs
		2	1014			µs
<i>tReady_mod2</i>	Sync Pulse (RE) to SO Answer ReadyToTransmit	0			1014	µs
		1			1165	µs
		2			1014	µs
<i>tRESync</i>	Get2 SS Rising Edge to Sync Pulse (RE)		93			µs

Table 17 – Trigger Modes Timing Specification (Mode 2, VDD = 3.3V)

Items	Definition	Marker	Min	Typ	Max	Unit
<i>tRERE_mod3</i>	Get3 SS RE to RE	0	1102			µs
		1	1253			µs
		2	1102			µs
<i>tReadyRE_mod3</i>	Get3 SS RE to DSP Completion	0			1102	µs
		1			1253	µs
		2			1102	µs
<i>tREFE_mod3</i>	Get3 SS Rising to Falling		105			µs
<i>tReadyFE_mod3</i>	Get3 SS RE to SO Answer ReadyToTransmit				105	µs

Table 18 – Trigger Modes Timing Specification (Mode 3, VDD = 3.3V)

14.9. Opcode Table

Opcode		MOSI Message	Opcode		MISO Message
19d	0x13	GET1	n/a		Regular Data Packet
20d	0x14	GET2			
21d	0x15	GET3	45d	0x2D	Get3Ready
1d	0x01	MemoryRead	2d	0x02	MemoryRead Answer
3d	0x03	EEPROMWrite	4d	0x04	EEPROMWrite Challenge
5d	0x05	EEChallengeAns	40d	0x28	EEReadAnswer
15d	0x0F	EEReadChallenge	14d	0x0E	EEPROMWrite Status
16d	0x10	NOP / Challenge	17d	0x11	Challenge/NOP MISO Packet
22d	0x16	DiagnosticDetails	23d	0x17	Diagnostics Answer
24d	0x18	OscCounterStart	25d	0x19	OscCounterStart Acknowledge
26d	0x1A	OscCounterStop	27d	0x1B	OscCounterStopAck+CounterValue
47d	0x2F	Reboot			
49d	0x31	Standby	50d	0x32	StandbyAck
			61d	0x3D	Error frame
			62d	0x3E	NothingToTransmit (NTT)
			44d	0x2C	Ready Message (first SO after POR)

Table 19 – Opcode Table

14.10. Timing specifications per Opcode, and next allowed messages

For each slave-in message, the timing between the slave-select-rising-edge event and the slave-select-falling event, as depicted below, is specified.



Figure 14 – Timing diagram

Op	MOSI Message	tREFE	Next allowed slave-in message
19	GET1	tREFE_mod1	GET1, MemoryRead, DiagDetails, NOP
20	GET2 followed by Sync	tSyncFE	GET2, MemoryRead, DiagDetails, NOP
21	GET3	tREFE_mod3	GET3, MemoryRead, DiagDetails, NOP
1	MemoryRead	tShort	MemoryRead, DiagDetails, NOP
3	EEPROMWrite	tShort	EEReadChallenge
5	EEChallengeAns	teewrite	NOP
15	EEReadChallenge	tShort	EEChallengeAns
16	NOP / Challenge	tShort	All commands
22	DiagnosticDetails	tShort	All commands
24	OscCounterStart	tShort	OscCounterStop
26	OscCounterStop	tShort	NOP
47	Reboot	tStartup	See Startup Sequence
49	Standby	tShort	All commands

Table 20 – Response time and Next allowed slave-in messages

14.11. NOP Command and NOP Answer

#	7	6	5	4	3	2	1	0	#	7	6	5	4	3	2	1	0
1									0								
3	KEY [15:8]								2	KEY [7:0]							
5									4								
7	CRC								6	1	1	0	1	0	0	0	0

Table 21 – NOP(Challenge) MOSI Message (Opcode = 16)

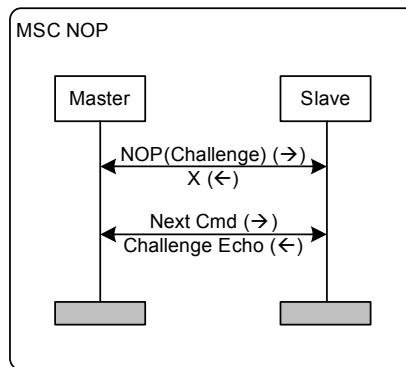

Figure 15 – NOP Message Sequence Chart

Note: the message X means “unspecified valid answer” and typically contains the answer of the previous command.

- Parameter *Key* : any 16 bit number

#	7	6	5	4	3	2	1	0	#	7	6	5	4	3	2	1	0
1									0								
3	KEY_ECHO [15:8]								2	KEY_ECHO [7:0]							
5	INVERTED KEY_ECHO [15:8]								4	INVERTED KEY_ECHO [7:0]							
7	CRC								6	1	1	0	1	0	0	0	1

Table 22 - Challenge Echo MISO Message (Opcode = 17)

- Parameter *Key_Echo* = *Key*
- Parameter *InvertedKey_Echo* = 65535 - *Key* (meaning bit reversal).

14.12. OscCounterStart and OscCounterStop Commands

The SCI Master can evaluate the slave’s internal oscillator frequency by the use of the *OscCounterStart* and *OscCounterStop* commands. This first command enables in the MLX90363 a software counter whereas the second command stops it and returns the counter value.

#	7	6	5	4	3	2	1	0	#	7	6	5	4	3	2	1	0
1									0								
3									2								
5									4								
7	CRC								6	1	1	0	1	1	0	0	0

Table 23 – OscCounterStart Slave-In message (opcode 24)

#	7	6	5	4	3	2	1	0	#	7	6	5	4	3	2	1	0
1									0								
3									2								
5									4								
7	CRC								6	1	1	0	1	1	0	0	1

Table 24 – *OscCounterStart* Acknowledge Slave-Out message (opcode 25)

#	7	6	5	4	3	2	1	0	#	7	6	5	4	3	2	1	0
1									0								
3									2								
5									4								
7	CRC								6	1	1	0	1	1	0	1	0

Table 25 – *OscCounterStop* Slave-In message (opcode 26)

#	7	6	5	4	3	2	1	0	#	7	6	5	4	3	2	1	0
1									0								
3	CounterValue[14:8]								2	CounterValue[7:0]							
5									4								
7	CRC								6	1	1	0	1	1	0	1	1

Table 26 – *OscCounter* Slave-Out message (opcode 27)

- Parameter *CounterValue* represents the time between the two events *OscCounterStart* Slave Select Rising Edge and *OscCounterStop* Slave Select Rising Edge, in microsecond, and for an oscillator frequency equal to 19MHz exactly.

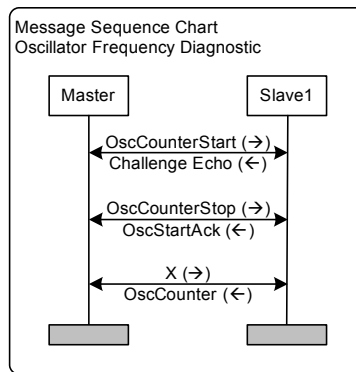

Figure 16 – Oscillator Frequency Diagnostic Message Sequence Chart

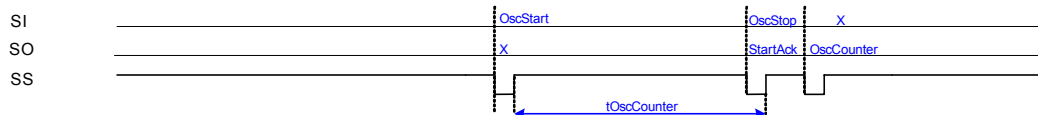

Figure 17 – Oscillator Frequency Diagnostic Timing Diagram (SCI)

Parameter	Symbol	Test Conditions	Min	Typ	Max	Units
	tOscCounter		500	1000	30000	us

14.13. Protocol Errors Handling

Error Item	Error definition	Condition	Detection	Slave Actions	MISO Message
IncorrectBitCount	Slave In Message bit count $\neq 64$	all modes	FW reads the HW bit counter	Ignore Message + Re-init Protocol	Error Message (incorrect bitcount = 1)
IncorrectCRC	Slave In Message has a CRC Error	all modes	FW computes CRC	Ignore Message + Re-init Protocol	Error Message (incorrect crc = 1)
IncorrectOpcode	Invalid Slave in Message	all modes	FW	Ignore Message + Re-init Protocol	Error Message (incorrect opcode = 1)
$t_{REFE} < t_{Ready_mod1}$	Regular Message Readback occurs to early	Trigger mode 1	Interrupt occurring to early + Fw reads HW bit + Protection interrupt	Ignore Frame + Re-init Protocol	NTT message
$t_{SyncFE} < t_{Ready_mod2}$	Regular Message Readback occurs to early	Trigger mode 2	Interrupt occurring to early + Fw reads HW bit + Protection interrupt	Ignore Frame + Re-init Protocol	NTT message
$t_{RESync} Violation$	Sync Pulse occurring to early	Trigger mode 2	none. The Sync pulse is pending internally.	none (but the sync pulse is not treated immediately)	Valid message. Note: This violation can cause a $T_{SyncFE} < T_{Ready_mod2}$ violation.
$t_{RERE_mod3} < t_{Ready_mod3}$	Regular Message Readback occurs to early	Trigger mode 3	Protection interrupt	Re-init Protocol	NTT message
$t_{REFE_mod3} < t_{Ready_FE_mod3}$	Regular Message Readback occurs to early	Trigger mode 3	Protection interrupt	Re-init Protocol	NTT message
TimeOut	Regular Message Readback occurs to late	all modes	Timer Interrupt	MISO Frame = NTT + Re-init Protocol	NTT message

Table 27 – Protocol Errors Handling (Slave standpoint)

Error Items/Events	Associated Slave Event	Master recommended actions	Associated Slave Actions	Next MISO message
Receive NTT	Receive NTT	Protocol re-initialization	Protocol re-initialization	Error Message * (TimeViolation = 1)
Receive Incorrect CRC Receive Incorrect Opcode	undetected event	Protocol re-initialization	none	Normal message
Receive Error Message	Send Error Message	Protocol re-initialization	none	Normal message
Receive an unexpected <i>DiagDetails</i> message	Run in fail-safe mode	Protocol re-initialization + Slave reset	none	<i>DiagDetails</i> message

Table 28 – Protocol Errors Handling (Master standpoint)

Note 1: On NTT or Error messages, master should consider that the last command is ignored by the slave, and it should therefore, either resend the command, or more generally re-initialize the protocol.

Note 2: After protocol re-initialization, master can diagnose the communication with a NOP command.

Note 3: A slave-out error message implicitly means that the slave has re-initialized the communication and is therefore ready to receive any commands.

14.14. Ready, Error and NTT Messages

After power-on-reset, the first slave-out message is a *Ready* message.

#	7	6	5	4	3	2	1	0	#	7	6	5	4	3	2	1	0
1	FWVersion[15:8]								0	HWVersion[7:0]							
3									2								
5									4								
7	CRC								6	1	1	1	0	1	1	0	0

Table 29 - Ready Slave-out Message (Opcode = 44)

The MLX90363 reports protocol errors using the *Error* message defined below. Diagnostics Errors (as opposed to protocol errors) are reported with the bits E1 and E0 of the regular message.

#	7	6	5	4	3	2	1	0	#	7	6	5	4	3	2	1	0
1									0	ERROR CODE							
3									2								
5									4								
7	CRC								6	1	1	1	1	1	1	0	1

Table 30 - Error Message MISO (Opcode = 61)

The description of the parameter *ErrorCode* is given in the table below.

Code	Description of Error CODE
1	Incorrect BitCount
2	Incorrect CRC
3	Answer = NTT message Two reasons: Answer Time-Out or Answer not Ready
4	OPCODE not valid

In most of the timing violations, the slave answers with a NTT message. A NTT message is stored in the slave's ROM (as opposed to the slave's RAM). NTT messages are typically seen in case of timing violation: either the firmware is still currently processing the previous SCI command, or a time-out occurred (see GET). In normal operation, NTT messages are not supposed to be observed: the Master is supposed to respect the protocol timings defined.

#	7	6	5	4	3	2	1	0	#	7	6	5	4	3	2	1	0
1			1				1		0				1				1
3		1				1			2			1	1			1	1
5		1	1			1	1		4		1		1		1		1
7	CRC								6	1	1	1	1	1	1	1	0

Table 31 – NTT (Nothing To Transmit) Message (Opcode = 62)

14.15. *DiagnosticsDetails* commands

This is the only function that can be combined with a regular message.

#	7	6	5	4	3	2	1	0	#	7	6	5	4	3	2	1	0
1									0								
3									2								
5									4								
7	CRC								6	1	1	0	1	0	1	1	0

Table 32 – *DiagnosticsDetails* Slave In Command (opcode =22)

Use *DiagnosticDetails* to get a detailed analysis of the diagnostics.

#	7	6	5	4	3	2	1	0	#	7	6	5	4	3	2	1	0
1	D15	D14	D13	D12	D11	D10	D9	D8	0	D7	D6	D5	D4	D3	D2	D1	D0
3	FSMERC		ANADIAGCNT						2	D23	D22	D21	D20	D19	D18	D17	D16
5									4								
7	CRC								6	1	1	0	1	0	1	1	1

Table 33 - Diagnostics *DiagnosticDetails* Master In message (Opcode = 23)

- Diagnostic bit *Dx* : see Section 18
- Parameter *DIGDIAGCNT* is a sequence loop counter referring to the digital-class diagnostics (B2, B3, B4, B5)
- Parameter *ANADIAGCNT* is a sequence loop counter referring to the analog-class diagnostics (all others).

If *FSMERC* = 3, *ANADIAGCNT* takes another meaning:

- 193 protection error interruption happened
- 194 invalid address error interruption happened
- 195 program error interruption happened
- 196 exchange error interruption happened
- 197 not connected error interruption happened
- 198 Stack Interrupt
- 199 Flow Control Error

- Parameter *FSMERC* reports the root-cause of entry in fail-safe mode
 - *FSMERC* = 0 : the chip is not in fail safe mode
 - *FSMERC* = 1 : BIST error happened and the chip is in fail safe mode
 - *FSMERC* = 2 : digital diagnostic error happened and the chip is in fail safe mode
 - *FSMERC* = 3 : one of the 5 error interruptions listed above happened and the chip is in fail safe mode

14.16. MemoryRead message

#	7	6	5	4	3	2	1	0	#	7	6	5	4	3	2	1	0
1	ADD0[15:8]								0	ADD0[7:0]							
3	ADD1[15:8]								2	ADD1[7:0]							
5									4								
7	CRC								6	1	1	0	0	0	0	0	1

Table 34 – MemoryRead Master-Out Slave-In Message (Opcode = 1)

MemoryRead returns two EEPROM or RAM words respectively pointed by the parameters ADDR0, ADDR1.

- The parameter ADDR_x has three valid ranges: 0...254 for RAM access, 0x1000...0x103E for EEPROM access, and 0x4000...0x5FFE for ROM access

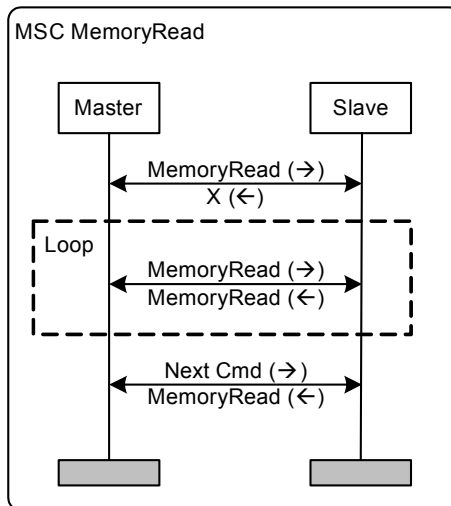

Figure 18 – MSC for RAM/ROM/EEPROM Memory Read

Note: Enter the loop for complete memory dumps.

MemoryRead Master-In Message (opcode 0x02)

The address *Addr* may be valid or not:

Case of validity: MemoryRead returns normally the data word pointed by *Addr*

Case of invalidity: MemoryRead returns *DataWord* = 0.

Note: FW makes sure that invalid addresses do not cause memory access violation

#	7	6	5	4	3	2	1	0	#	7	6	5	4	3	2	1	0
1	DATA[15:8] AT ADD0								0	DATA[7:0] AT ADD0							
3	DATA[15:8] AT ADD1								2	DATA[7:0] AT ADD1							
5									4								
7	CRC								6	1	1	0	0	0	0	1	0

Table 35 – MemoryRead MISO Packet (Opcode = 2)

14.17. EepromWrite Message

#	7	6	5	4	3	2	1	0	#	7	6	5	4	3	2	1	0	
1	0	0	ADDRESS[5:0] ⁽²⁵⁾						0									
3	KEY[15:8]								2	KEY[7:0]								
5	DATA WORD[15:8]								4	DATA WORD[7:0]								
7	CRC								6	1	1	0	0	0	0	1	1	

Table 36 – EEPROMWrite MOSI Message (Opcode = 3)

The EEPROM data consistency is guaranteed through two protection mechanisms: A and B.

Protection A: The parameter ADDRESS should match the parameter KEY.

The key associated to each address is public. Protection against erroneous write (in the field) is guaranteed as long as the keys are not stored in the master (ECU), but in the calibration system, which is typically a CAN or LIN Master.

Protection B: Slave challenges the Master with a randomly generated ChallengeKey, expects back this key exclusive-or with 0x1234

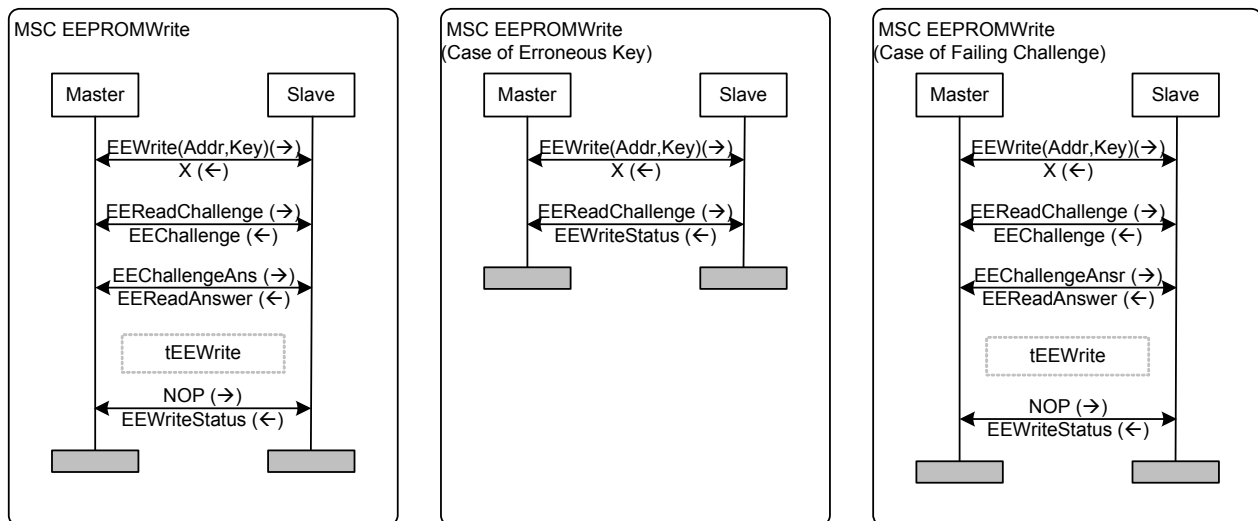

Figure 19 – MSCs EEPROMWrite

ADDRESS[6:5]	0	1	2	3	4	5	6	7
0	17485	31053	57190	57724	7899	53543	26763	12528
1	38105	51302	16209	24847	13134	52339	14530	18350
2	55636	64477	40905	45498	24411	36677	4213	48843
3	6368	5907	31384	63325	3562	19816	6995	3147

Table 37 – EEPROM Write Public Keys

#	7	6	5	4	3	2	1	0	#	7	6	5	4	3	2	1	0
1									0								
3									2								
5									4								
7	CRC								6	1	1	0	0	1	1	1	1

Table 38 – EEPROMWrite ReadChallenge Slave-In Message (Opcode = 15)

²⁵ The value of the ADDRESS[5:0] shall be even.

#	7	6	5	4	3	2	1	0	#	7	6	5	4	3	2	1	0
1									0								
3	CHALLENGE KEY [15:8]							2	CHALLENGE KEY [7:0]								
5									4								
7	CRC							6	1	1	0	0	0	1	0	0	

Table 39 – EEPROMWrite EEChallenge Slave-Out Message (Opcode = 4)

- The parameter *ChallengeKey* is randomly generated by the sensor, and should be echoed because of the next command

#	7	6	5	4	3	2	1	0	#	7	6	5	4	3	2	1	0
1									0								
3	KEY ECHO [15:8]							2	KEY ECHO [8:7]								
5	INVERTED KEY ECHO [15:8]							4	INVERTED KEY ECHO [8:7]								
7	CRC							6	1	1	0	0	0	1	0	1	

Table 40 – EEPROMWrite ChallengeAns Slave-In Message (Opcode = 5)

- The parameter *KeyEcho* should match *ChallengeKey* xor'ed with 0x1234.
- The parameter *InvertedKeyEcho* should match *KeyEcho* after bit reversal.

#	7	6	5	4	3	2	1	0	#	7	6	5	4	3	2	1	0
1									0								
3									2								
4									4								
7	CRC							6	1	1	1	0	1	0	0	0	

Table 41 – EEReadAnswer Slave-Out Message (Opcode = 40)

#	7	6	5	4	3	2	1	0	#	7	6	5	4	3	2	1	0
1									0					CODE			
3									2								
4									4								
7	CRC							6	1	1	0	0	1	1	1	0	

Table 42 – EEPROMWriteStatus Slave-Out Message (Opcode = 14)

- The parameter *Code* details the exact cause of EEPROM write failure

Code	Description of EEPROM Write Failure
1	Success
2	Erase/Write Fail
4	EEPROM CRC Erase/Write Fail
6	Key Invalid
7	Challenge Fail
8	Odd Address

The command *Reboot* must be sent after a series of EEPROM writes, to make sure that the new EEPROM parameters are taken into account.

14.18. Reboot

Reboot is a valid command in the following three cases.

1. After an EEPROM write
2. In fail-safe mode
3. In standby mode

In normal mode, *Reboot* reports wrong opcode.

Reboot causes a system reset identical to a true power-on reset. Start-up timings and sequences are applicable for the *reboot* message.

Reboot, after EEPROM programming

It is meant to force the FW to refresh the EEPROM cache and IO space after a series of EEPROM write commands. It forces the FW to take into account all the changes (modes enabling, disabling...) including those that are not cached.

Reboot, in fail-safe mode

ECU can issue a *reboot* message to exit the fail-safe mode before the watchdog time-out, for a fast recovery.

#	7	6	5	4	3	2	1	0	#	7	6	5	4	3	2	1	0
1									0								
3									2								
4									4								
7	CRC								6	1	1	1	0	1	1	1	1

Table 43 – Reboot (Opcode = 47)

14.19. Standby

Standby sets the sensor in Standby mode: the digital clock is stopped and some analog blocks are switched off. The SCI clock remains active, allowing the sensor to be responsive to SCI messages.

The first SCI message received while in Standby wakes up the sensor. The standby mode is precisely exited on the SS rising edge. The first message following a *Standby* message is normally interpreted by the sensor. It can be NOP, a GET or anything else.

#	7	6	5	4	3	2	1	0	#	7	6	5	4	3	2	1	0
1									0								
3									2								
4									4								
7	CRC								6	1	1	1	1	0	0	0	1

Table 44 – Standby (Opcode = 49)

The sensor answer to *Standby* is *StandbyAck* (opcode 50).

After resuming, the (E1, E0) error bits of the 6 following *GET* messages shall be ignored.

14.20. Start-up Sequence (Serial Communication)

The MLX90363 serial interface is enabled after the internal start-up initializations and start-up checks. Note: The start-up sequence of the MLX90363 firmware is described at chapter 19.1.

The recommended SCI start-up sequences (Master – Slave) are depicted in the following message sequence charts, and timing diagrams. It usually starts with a NOP SI message. Ready is the first SO message.

For safety critical applications, Melexis recommends performing two extra checks prior to the request of the first regular data: oscillator frequency check and a readback of the diagnostic details (ROM, RAM, ADC Monitor...)

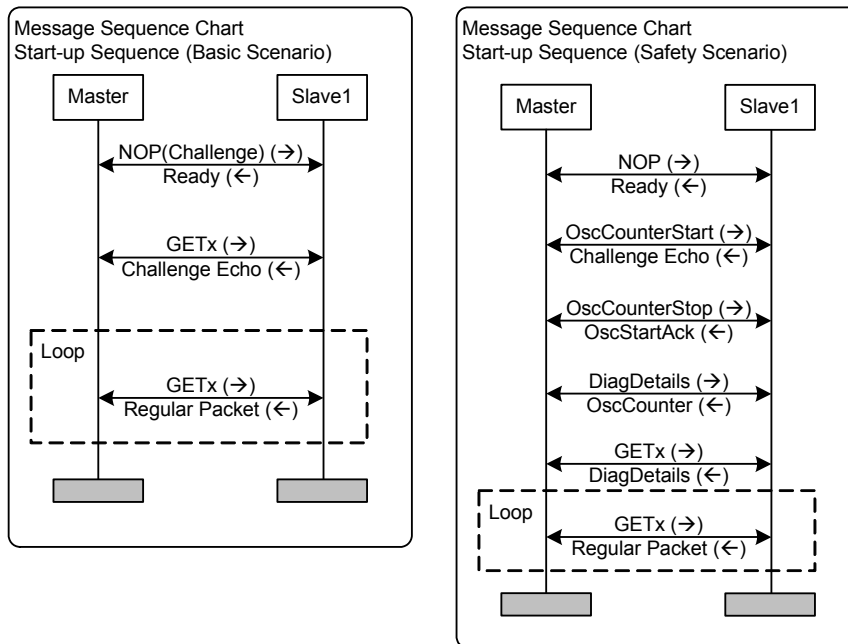

Figure 20 – MSCs Start-up sequence examples (basic and safety critical scenario)

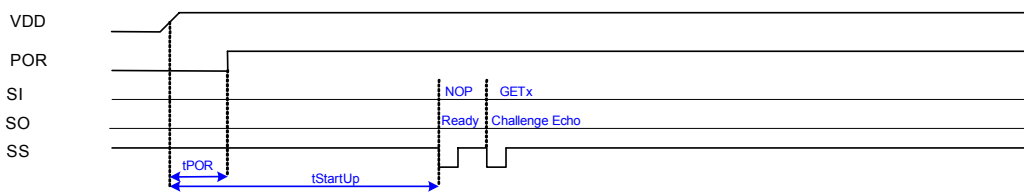

Figure 21 – Start-up sequence, basic scenario, timing diagram

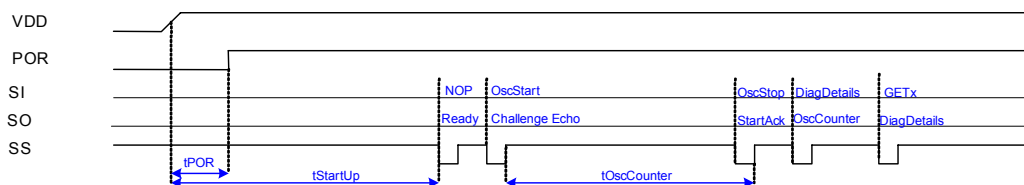

Figure 22 – Start-up sequence, safety critical scenario, timing diagram

Notes:

- The timing $t_{StartUp}$ is specified at chapter Timing Specifications (Section 10)
- The slave answers with *NTT* in case the first SI message occurs prior the end of the initial checks.
- The NOP - Challenge Echo is meant to diagnose the SCI link.

14.21. Allowed sequences

Only the message sequences described in this datasheet are accepted by the sensor.

A few more are described below; they combine GET1 or GET2 with MemoryRead or DiagDetails. The particular timings associated to these sequences do not overrule the general timing specifications.

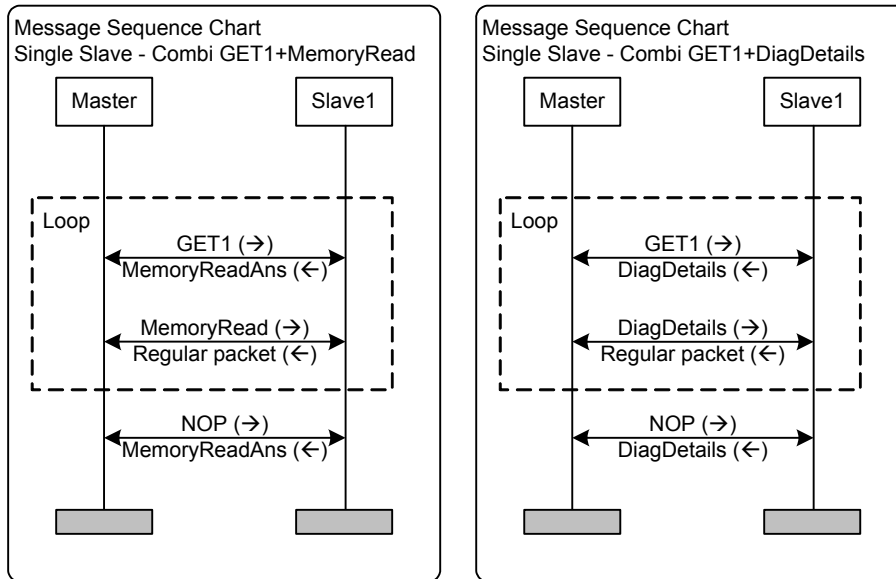

Figure 23 – MSCs Combi sequences GET1+MemoryRead and GET1+DiagDetails

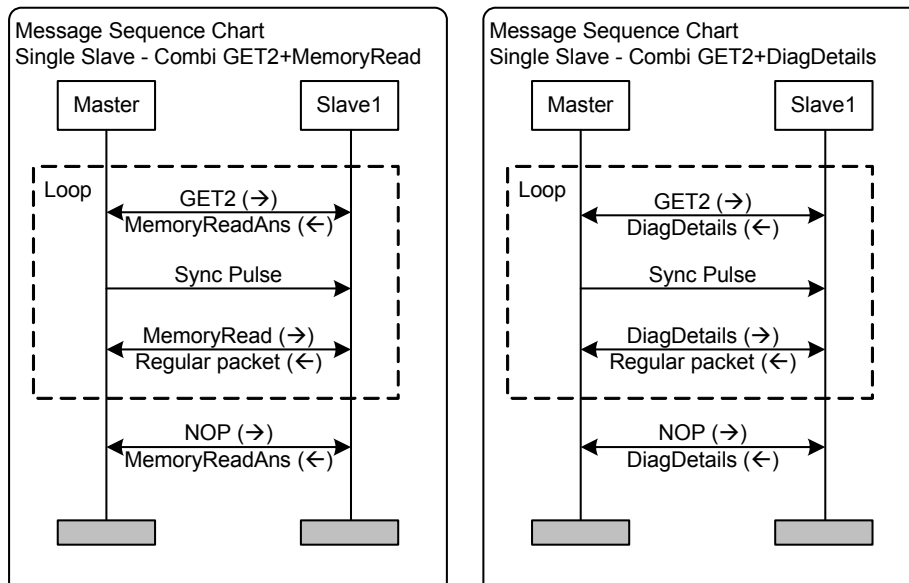

Figure 24 – MSCs Combi sequences GET2+MemoryRead and GET2+DiagDetails

15. MLX90363 Traceability Information

Every device contains a unique ID that is stored in the EEPROM. Melexis strongly recommends storing this value during the EOL (end-of-line) programming to ensure full traceability of the product.

These parameters shall never be erased during the EOL programming.

Parameter	Comments	Address	Default Values	Parameter
		(Hexa)	-	# bit
MLXID	Traceability Information	1012[15:0]	MLX	48
		1014[15:0]		
		1016[15:0]		

16. MLX90363 End-User Programmable Items

The list below describes the parameters that are available to the customer during EOL programming. The parameters will be programmed through the *EepromWrite* Message (section 14.17).

It must be noted that the data type of *Eepromwrite* Message is a word, and therefore it is mandatory to first readback the complete contents of the word before changing only the bits corresponding to the parameter.

Parameter	Comments	Address	Default Values	Parameter
		(Hexa)	-	# bit
MAPXYZ	XYZ Coordinates mapping	102A[2:0]	0	3
3D	Enabling of 3D formula (Joystick)	102A[3]	0	1
FILTER	Enabling of Signal Filter	102A[5:4]	0	2
VIRTUALGAINMAX	Electrical Gain Code Max	102E[15:8]	41	8
VIRTUALGAINMIN	Electrical Gain Code Min	102E[7:0]	0	8
KALPHA	Magnetic Angle Formula Parameter	1022[15:0]	1.4	16
KBETA	Magnetic Angle Formula Parameter	1024[15:0]	1.4	16
SMISM + SEL_SMISM	Magnetic Angle Formula Parameter	1032[15:0]	1	16
ORTH_B1B2	Magnetic Angle Formula Parameter	1026[7:0]	0	8
KT	Magnetic Angle Formula Parameter	1030[15:0]	1	16
FHYST	Hysteresis Value (Alpha + Beta)	1028[15:8]	MLX	8
PINFILTER	SCI Input Pins: EMC: Filter Bandwidth	1001[1:0]	1	2
USERID	User Identification	103A[15:0]	0001	16
		103C[15:0]	0003	16
FREE	Freely usable by user	1018[15:0]	0	40
		1026[15:8]		
		1028[7:0]		
		103E[7:0]		

Melexis strongly recommends checking the User Identification data (Parameters USERID) during EOL calibration.

17. MLX90363 Description of End-User Programmable Items

17.1. User Configuration: Device Orientation

MAPXYZ	Assignment	Note
0	B1 = X, B2 = Y, B3 = Z	
1	B1 = X, B2 = Z, B3 = Y	
2	B1 = Y, B2 = Z, B3 = X	
3	B1 = Y, B2 = X, B3 = Z	Use mode 0 instead
4	B1 = Z, B2 = X, B3 = Y	
5	B1 = Z, B2 = Y, B3 = X	

The values B1, B2 and B3 are inputs to the 2D/3D formula (see section 17.2).

The field coordinates X, Y, Z are relative to the device (See Section 23.3 and 23.6). The parameter MAPXYZ selects the application-dependent mapping of (X, Y, Z) to (B1, B2, B3).

17.2. User Configuration: Magnetic Angle Formula

Parameter 3D	Formula	Note
0	$Alpha = \arctan\left(\frac{B2}{B1}\right)$	extended to the full circle
1	$Alpha = \arctan\left(\frac{\sqrt{(KALPHA \times B3)^2 + (KT \times B2)^2}}{B1}\right)$ $Beta = \arctan\left(\frac{\sqrt{(KBETA \times B3)^2 + (KT \times B1)^2}}{B2}\right)$	extended across B1=0 and B2=0 max 180deg

17.3. User Configuration: 3D=0 formula trimming parameters SMISM and ORTH_B1B2

17.3.1. Magnetic Angle ∠XY

Parameter	Address (hex)	Value
SMISM + SEL_MISM	1032[15:0]	Trimmed by MLX
ORTH	1038[7:0]	Trimmed by MLX
ORTH_SEL	102C[8]	0
MAPXYZ	102A[2:0]	0

This is the default condition as programmed by MLX. In such case, no front-end calibration is needed from the customer.

17.3.2. Magnetic Angle $\angle XZ$ and $\angle YZ$

Parameter	Address (hex)	Range	Value
SEL_SMISM	1032[15]	0 or 1	0 or 1
SMISM	1032[14:0]	[0..2]	TYP = 1.4
ORTH_SEL	102C[8]	0 or 1	1
ORTH_B1B2	1026[7:0]	[0..2]	TYP = 0
MAPXYZ	102A[2:0]	1, 2, 4 or 5	1, 2, 4 or 5

If the magnetic angle $\angle XZ$ or $\angle YZ$ is read, Melexis strongly recommends calibrating the front-end parameters⁽²⁶⁾ in order to reduce the magnetic accuracy error (see Section 11):

1) Phase Error

$$B2 = B1 - B2 * ORTH_B1B2 / 1024$$

Where ORTH_B1B2 is the phase mismatch between the B1 and B2 signals.

2) Sensitivity Mismatch between B1 and B2

The parameter SMISM is selected in such a way that:

i. Case $|B1| > |B2| \rightarrow SEL_SMISM = 0$

$B1 * SMISM[14:0] / 2^{15}$ and B2 have the same amplitude.

ii. Case $|B2| < |B1| \rightarrow SEL_SMISM = 1$

B1 and $B2 * SMISM[14:0] / 2^{15}$ have the same amplitude.

17.4. User Configuration: 3D=1 formula trimming parameters KALPHA, KBETA, KT

The values KALPHA, KBETA and KT are inputs to the 3D formula (see section 17.2) and allow a targeted reduction of the linearity error through a normalization of the raw signals and a correction prior to the ATAN function.

Parameter	Value	Range	Typ.
KALPHA	0 ... $2^{16}-1$	[0..2]	1.4
KBETA	0 ... $2^{16}-1$	[0..2]	1.4
KT	0 ... $2^{16}-1$	[0..2]	1

²⁶ See AN Front End Calibration of MLX90363 in XZ and YZ Mode – Application note to be created in 2011.

17.5. User Configuration: Filter

The MLX90363 features 3 FIR filter modes controlled with Filter = 1...3. The transfer function is described below:

$$y_n = \frac{1}{\sum_{i=0}^j a_i} \sum_{i=0}^j a_i x_{n-i}$$

The characteristics of the filters No. 0 to 3 is given in the following table.

Filter No. (j)	0	1	2	3
Type	Disable	Finite Impulse Response		
Coefficients a ₀ ... a ₅	N/A	11	1111	12221
Title	No Filter	Extra Light	Light	Medium
99% Response Time	1	2	4	5
Efficiency RMS (dB)	0	3.0	6.0	6.6

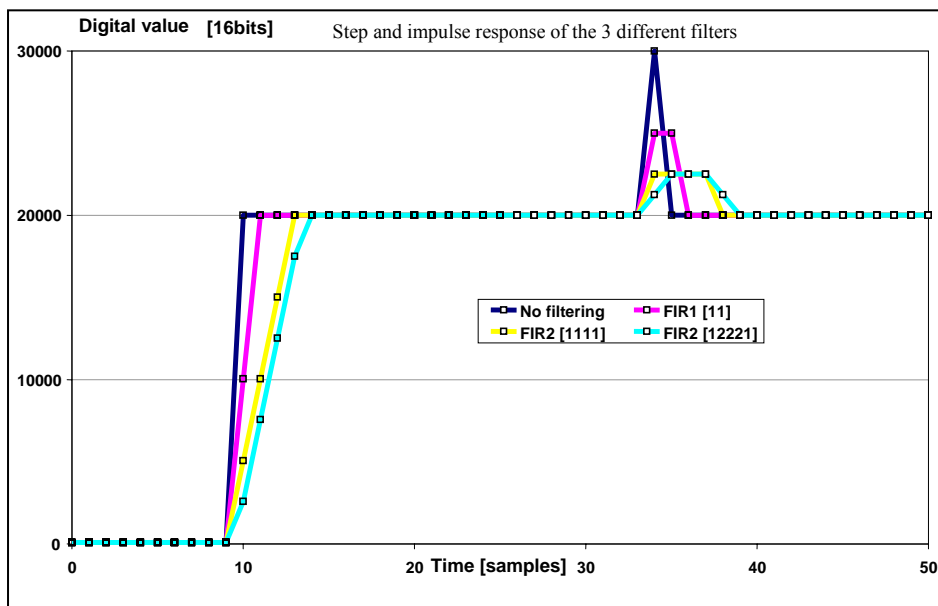

17.6. Virtual Gain Min and Max Parameters

The MLX90363 automatic gain control (AGC) loop selects the electrical gain code within the user-defined range VIRTUALGAINMIN...VIRTUALGAINMAX. Setting VIRTUALGAINMIN=VIRTUALGAINMAX means setting a fixed gain. The min and max virtual gain codes influence directly the sensitivity of the diagnostics D17-“Field Magnitude Too High” and D18-“Field Magnitude Too Low”.

17.7. Hysteresis FILTER

Parameter	Value	Note
FHYST	0 ... 255	1 LSB = 0.044 deg

The FHYST parameter is a hysteresis filter. The output value of the IC is not updated when the digital step is smaller than the programmed FHYST parameter value. The output value is modified when the increment is bigger than the hysteresis. The hysteresis filter reduces the resolution to a level compatible with the internal noise of the IC. The hysteresis must be programmed to a value close to the noise level.

17.8. EMC Filter on SCI Pins

The EEPROM parameter PINFILTER selects the level of filtering on the serial protocol input pins.

SCI clock frequency	PINFILTER Recommended value for higher EM Immunity
2MHz	1
1MHz	2
500kHz	3

17.9. Identification & FREE bytes

Parameter	Value	Unit
USERID	$0..(2^{31}-1)$	
FREE	$0..(2^{39}-1)$	

Identification number: 32 bits freely useable by Customer for traceability purpose.
The FREE bytes can also be used for identification or any other purposes.

17.10. Lock

The calibration parameters of the MLX90363 are locked.
To unlock the write, one must follow the write procedure described in section 14.17.

18. MLX90363 Self Diagnostic

The MLX90363 provides numerous self-diagnostic features which increase the safety integrity level of the IC, by diagnosing and reporting as many as 18 internal and external failure cases.

Diagnostic Item	Action	Bit	Notes
RAM March C- 10N Test	Fail-safe mode	D0	At Startup only
Watchdog BIST	Fail-safe mode	D1	At Startup only
ROM 16 bit Checksum	Fail-safe mode	D2	
RAM Test (continuous)	Fail-safe mode	D3	
CPU Register Functional Test	Fail-safe mode	D4	
EEPROM Calibration parameters (8 bit CRC)	Fail-safe mode	D5	
EEPROM Hamming Code DED (Dual Error Detection)	Fail-safe mode	D6	
EEPROM RAM Cache Error	Report ⁽²⁷⁾	D7	
ADC Block	Report	D8	Reference Voltage Unit (VCM) + 11 Input Levels
Bz sensitivity monitor ⁽²⁹⁾	Report (Optional)	D12	See Magnetic Frequency Spec.
Bx sensitivity monitor ⁽²⁹⁾	Report	D13	See Magnetic Frequency Spec.
By sensitivity monitor ⁽²⁹⁾	Report	D14	See Magnetic Frequency Spec.
Temperature sensor monitoring (based on redundancy)	Report, temp. value set to EE_T35	D15	
Temperature > 190 deg (± 20deg) Temperature < -80 deg (± 20deg)	Report, saturate temp. value	D16	External failure
Field magnitude too high (<i>Norm</i> > 99% ADC Span) ⁽²⁸⁾	Report	D17	External failure, given that AGC keeps <i>Norm</i> below 63.5%
Field magnitude too low (<i>Norm</i> < 20% ADC Span)	Report	D18	External failure, given that AGC keeps <i>Norm</i> above 47%
ADC clipping (X, Y, Z, two phases each)	Report	D19	External failure
Supply voltage monitor (VDD) and Regulator monitor (VDEC) ⁽²⁹⁾	Report (Optional)	D20	External failure
Firmware Flow monitoring	Fail-safe mode	n/a	
Read/Write Access out of physical memory	Fail-safe mode	n/a	
Stack Overflow	Fail-safe mode	n/a	
Write Access to protected area (IO and RAM Words)	Fail-safe mode	n/a	
Unauthorized entry in "SYSTEM" Mode	Fail-safe mode	n/a	
Serial Interface Protection Error	NTT Message ⁽³⁰⁾	n/a	
Watchdog Timeout	Reset ⁽³¹⁾	n/a	
Oscillator Frequency (Dedicated SCI Command)	n/a	n/a	Diagnostic performed by master
VDD > MT8V	MISO is HiZ	n/a	100% Hardware detection. No communication possible.

Figure 25 – Diagnostics List

²⁷ Reporting is done through the bits E0 and E1 of the regular messages or the bits Dx of the DiagnosticDetails message. See Table 8 for more details.

²⁸ $Norm = \max(\text{abs}(X), \text{abs}(Y), \text{abs}(Z))$

²⁹ Diagnostic to be disabled in the 3V3 application diagram (VDD = VDEC).

³⁰ The NTT Message is followed by an Error Message.

³¹ Resetting has the same effects as a POR: the next SO message is therefore *Ready*.

19. MLX90363 Firmware Flowcharts

19.1. Start-up sequence

The entry in operation mode is preceded by a startup phase or startup sequence, performing the built-in self tests (performed only once), the automatic analog gain adjustment, the temperature acquisition and a first execution of the built-in self diagnostics (also performed continuously afterwards). The start-up sequence ends with the enabling of the serial interface.

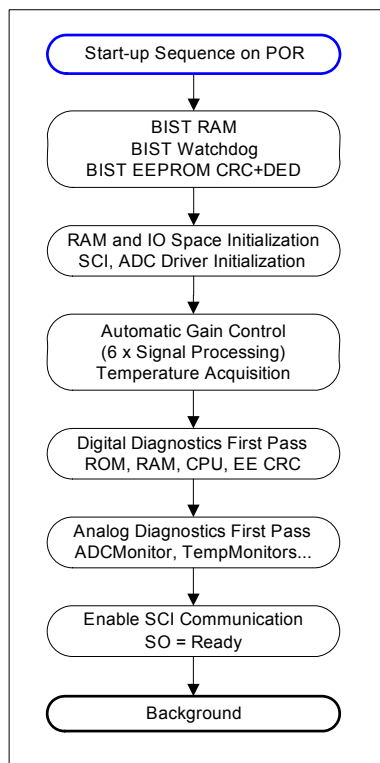

Figure 26 – Firmware start-up sequence

19.2. Signal Processing (GETx)

The digital signal processing performed by the firmware is depicted by the following diagram.

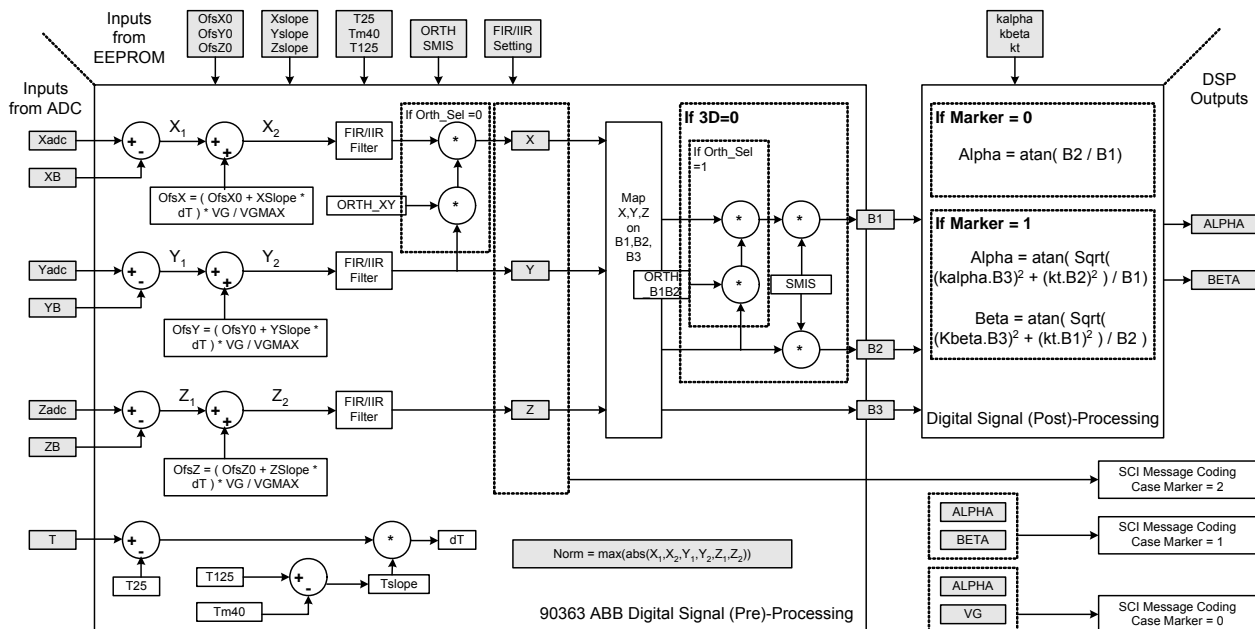

Figure 27 – Block Diagram of Signal Processing – Function model

19.3. Fail-safe Mode

The purpose of fail-safe mode is dual:

1. To increase the safety integrity, by blocking any position calculation and position reporting whenever a critical error (WD error, ROM Checksum, Firmware flow error...) is detected
2. To report the root cause of the failure

In fail-safe mode,

- The analog is [set] inactive
- The sensor waits for the master to initiate a reset
- Autonomous reset by watchdog after 100ms, i.e. watchdog running but will not be acknowledged
- Only SPI driver and communication handler is active. The only supported MOSI commands is
 - sciREBOOT
- Upon all SPI MOSI commands, the MISO message SPI_ERROR (= DiagDetailAnswer) is sent
- Diagnostics (analog and digital) and background are not running

Fail-safe mode – entry conditions

The fail-safe mode is entered upon:

- Critical error during initialization (RAM BIST, WD BIST, ROM Checksum, EEPROM CRC)
- Critical error during background/digital diagnostics (RAM continuous test, ROM test, EEPROM CRC)
- Exception, i.e. system level interrupts (Stack-overflow, invalid address, protection error, program error)
- FW flow error

19.4. Automatic Gain Control

The Virtual Gain code is updated at every *GET* message. The new code value is based on the field strength (Norm) of every raw component (X, Y, Z).

The Automatic Gain Control (AGC) makes sure that Norm is between 47% and 63.5%, by controlling the gain code within the range (VIRTUALGAINMIN, VIRTUALGAINMAX).

The algorithm gives a limitation in term flux density frequency, see Section 10 for specification.

It is not recommended to interrupt the *GET* message sequence, because AGC iterations are triggered by *GET* messages. If a pause cannot be avoided, the (E1, E0) error bits of the 6 following *GET* messages shall be ignored.

20. Recommended Application Diagrams

20.1. MLX90363 in SOIC-8 Package and 5V Application Diagrams

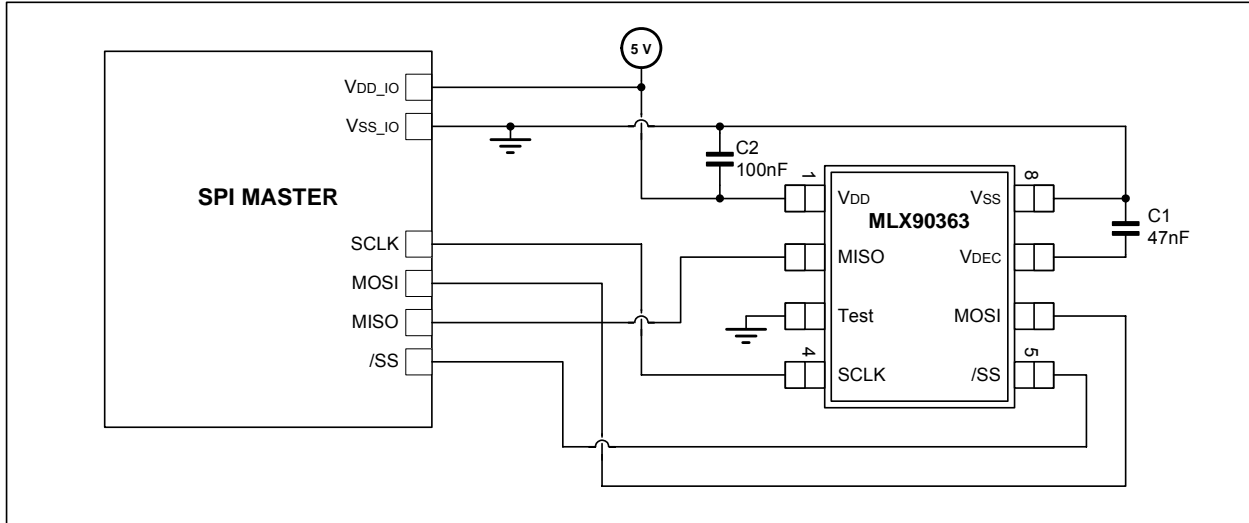

Figure 28 – Recommended wiring⁽³²⁾ for the MLX90363 in SOIC8 package and 5V Application Diagrams.

20.2. MLX90363 in SOIC-8 Package and 3V3 Application Diagrams

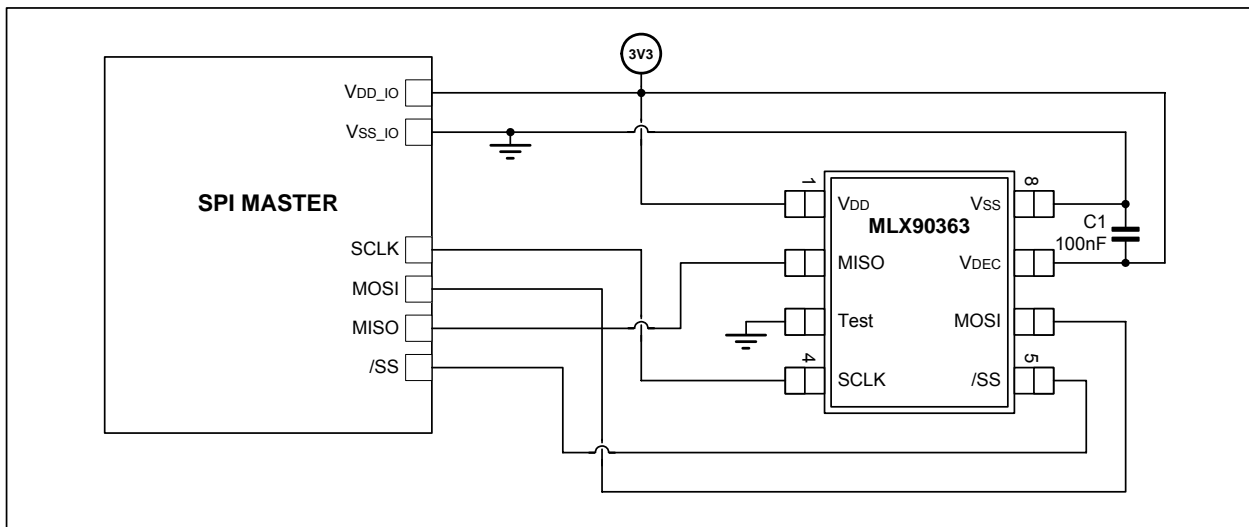

Figure 29 – Recommended wiring⁽³²⁾ for the MLX90363 in SOIC8 package and 3V3 Application Diagrams.

³² Wiring of the SCI signals must be kept short on the PCB. In other cases, Melexis advises to add 100Ω serial resistor on the SCLK, MOSI, MISO and /SS lines. Melexis also recommends doubling the C1 decoupling capacitor.

20.3. MLX90363 in TSSOP-16 Package and 5V Application Diagrams

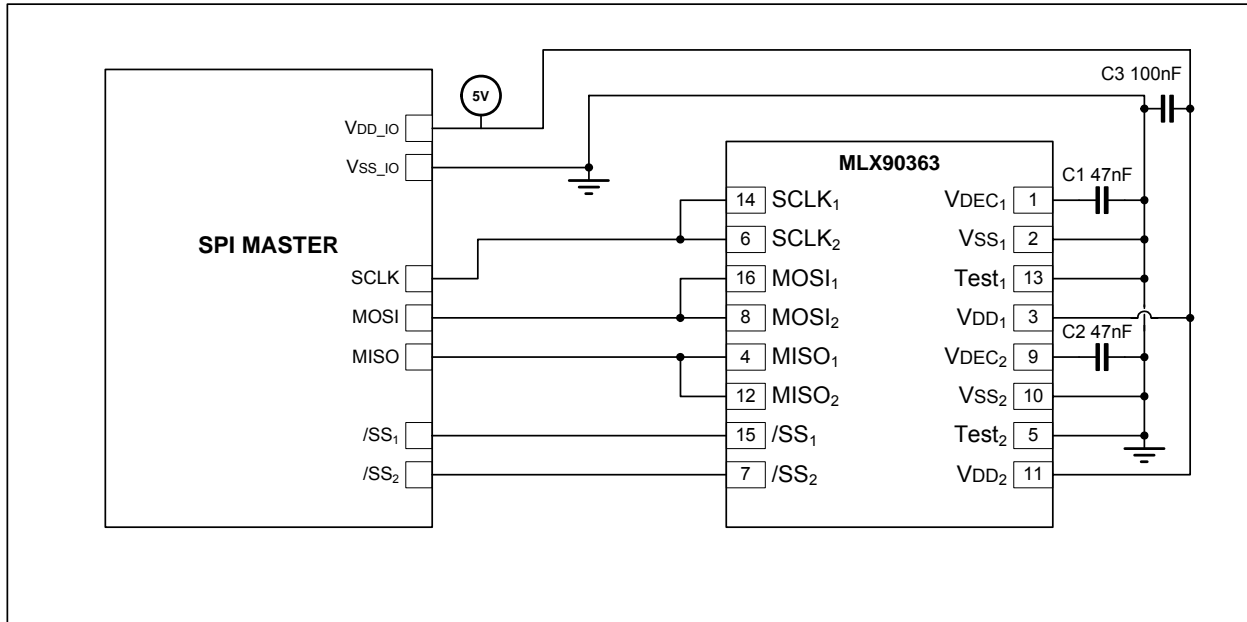

Figure 30 – Recommended⁽³³⁾ wiring for the MLX90363 in TSSOP16 package (dual die) and 5V Application Diagrams.

20.4. MLX90363 in TSSOP-16 Package and 3V3 Application Diagrams

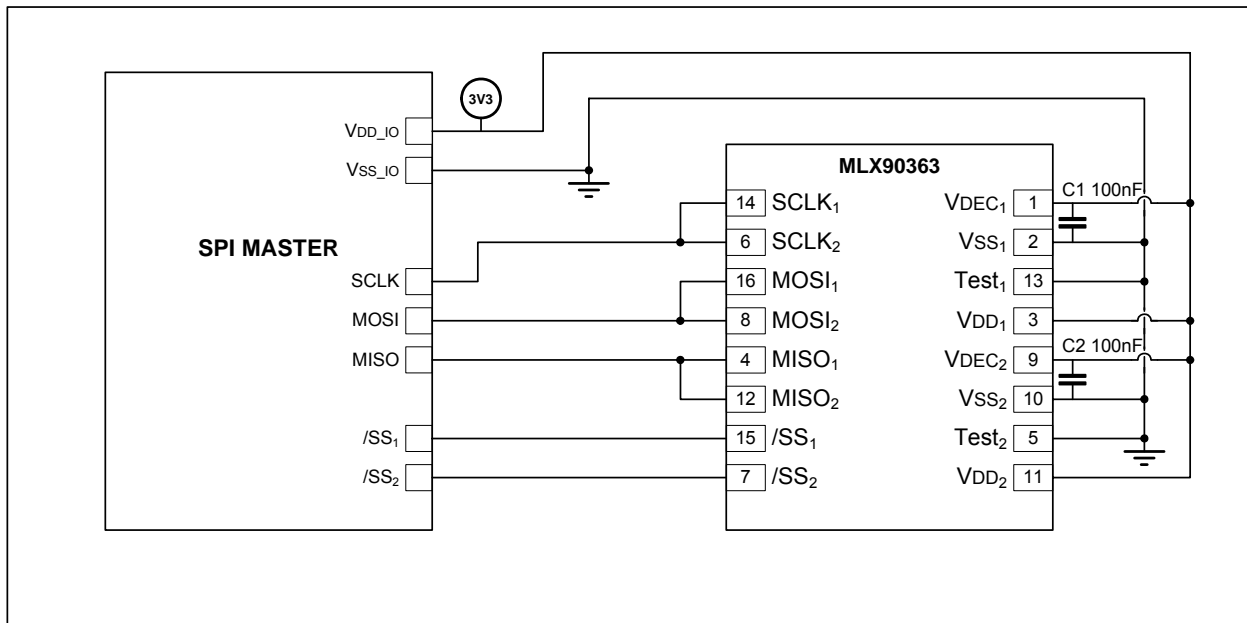

Figure 31 – Recommended⁽³³⁾ wiring for the MLX90363 in TSSOP16 package (dual die) and 3V3 Application Diagrams

³³ Wiring of the SCI signals must be kept short on the PCB. In other cases, Melexis advises to add 100Ω serial resistor on the SCLK, MOSI, MISO and /SS lines. Melexis also recommends to double the C1,C2 decoupling capacitors.

21. Standard information regarding manufacturability of Melexis products with different soldering processes

Melexis devices are qualified using state-of-the-art practices in accordance with automotive and environmental requirements.

Through qualifications, various soldering techniques are considered; please refer to “Soldering recommendations for Melexis products”

(http://www.melexis.com/Asset/Soldering_Application_Note_and_Recommendations_DownloadLink_5446.aspx) for more information.

For components normally soldered using Surface Mounted Device techniques (eg: Reflow process), Melexis has defined and qualified Moisture Sensitivity Level and Peak Temperature in accordance with the Jedec J-STD-020 standard. Delivered material is conditioned accordingly. Moisture Sensitivity Level and Peak Temperature information can be found on the label identifying the material.

In case you intend to use a reflow soldering process for through hole devices (Melexis' package codes: SA, UA, VA, VK, VM), please contact Melexis to verify your soldering process compatibility.

The application of Wave Soldering for SMD's is allowed only after consulting Melexis regarding assurance of adhesive strength between device and board.

Based on Melexis commitment to environmental responsibility, Europe legislations (Direction on the Restriction of the Use of Certain Hazardous substances, RoHS) and customer requests, Melexis has deployed Pb free leadfinish (typically Matte Tin) on all ASSP products.

For through hole devices (Melexis' package codes: SA, UA, VA, VK, VM) Trim&Form, please refer to “Trim & Form recommendations for Melexis products”

(http://www.melexis.com/Assets/Trim_and_form_recommendations_DownloadLink_5565.aspx) for more information.

22. ESD Precautions

Electronic semiconductor products are sensitive to Electro Static Discharge (ESD).

Always observe Electro Static Discharge control procedures whenever handling semiconductor products.

23. Package Information

23.1. SOIC8 – Package Dimensions

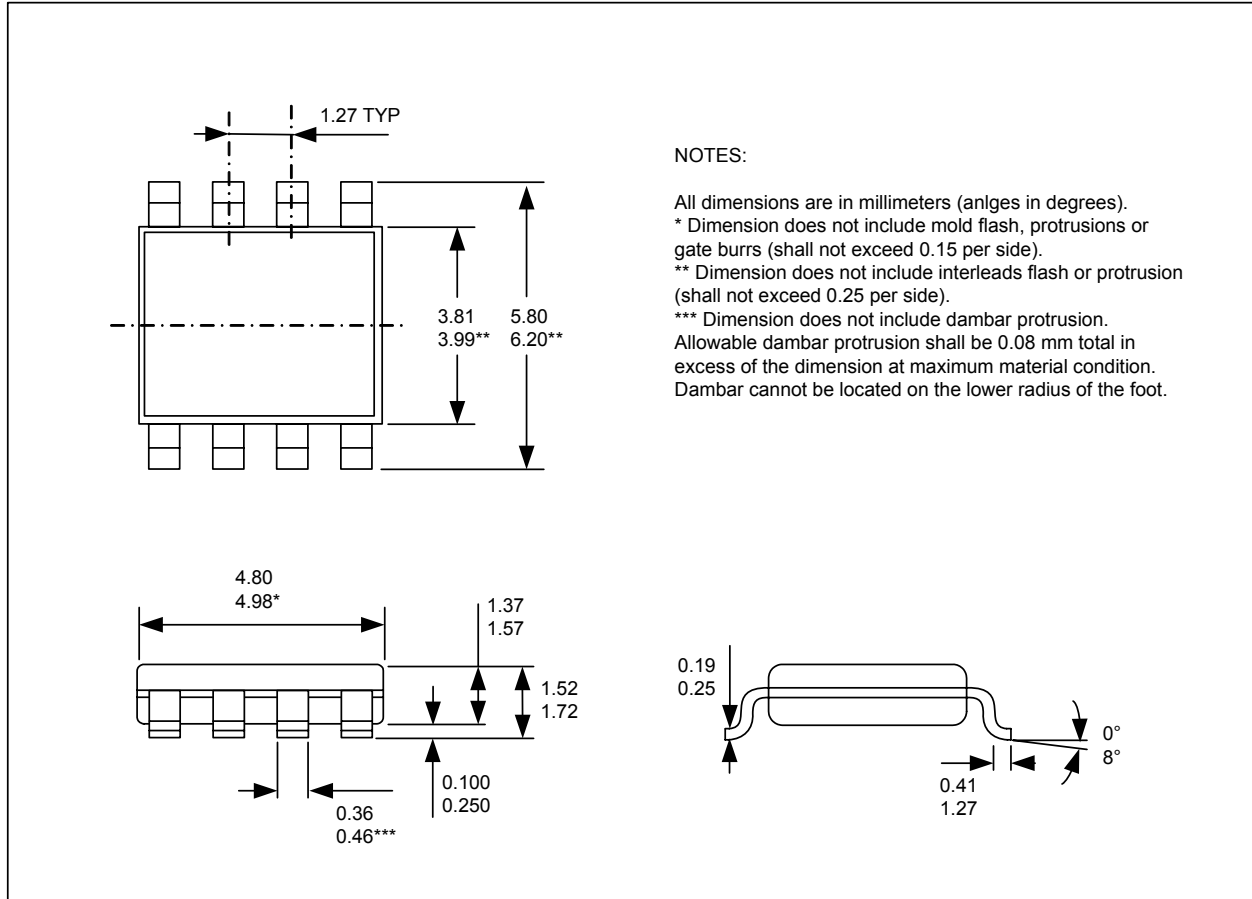

23.2. SOIC8 – Pinout and Marking

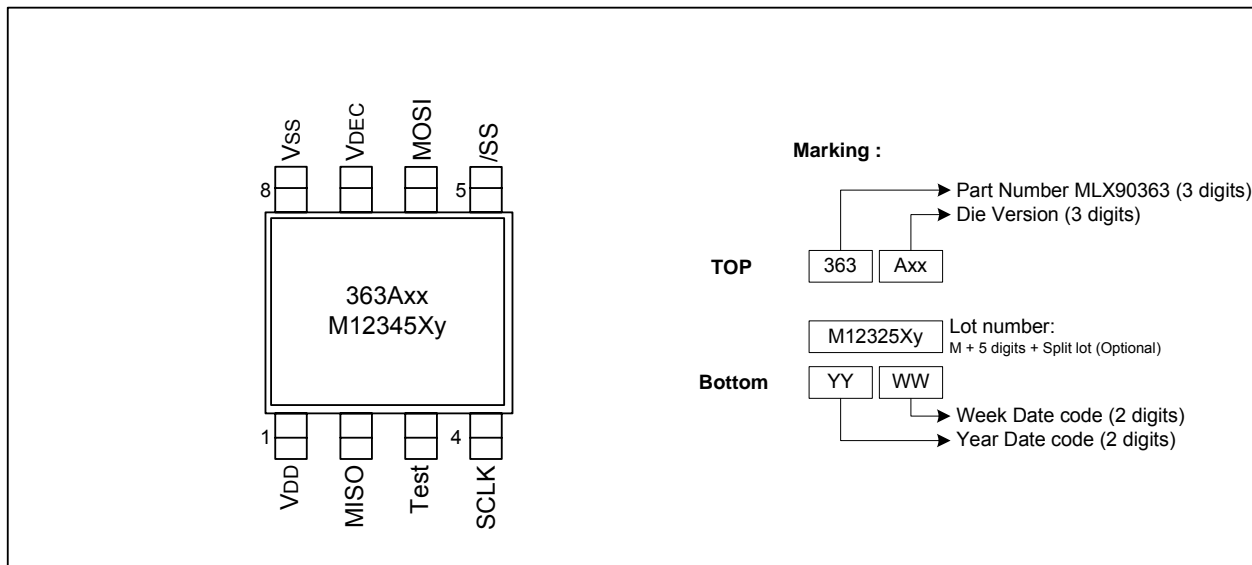

23.3. SOIC8 – IMC Positioning

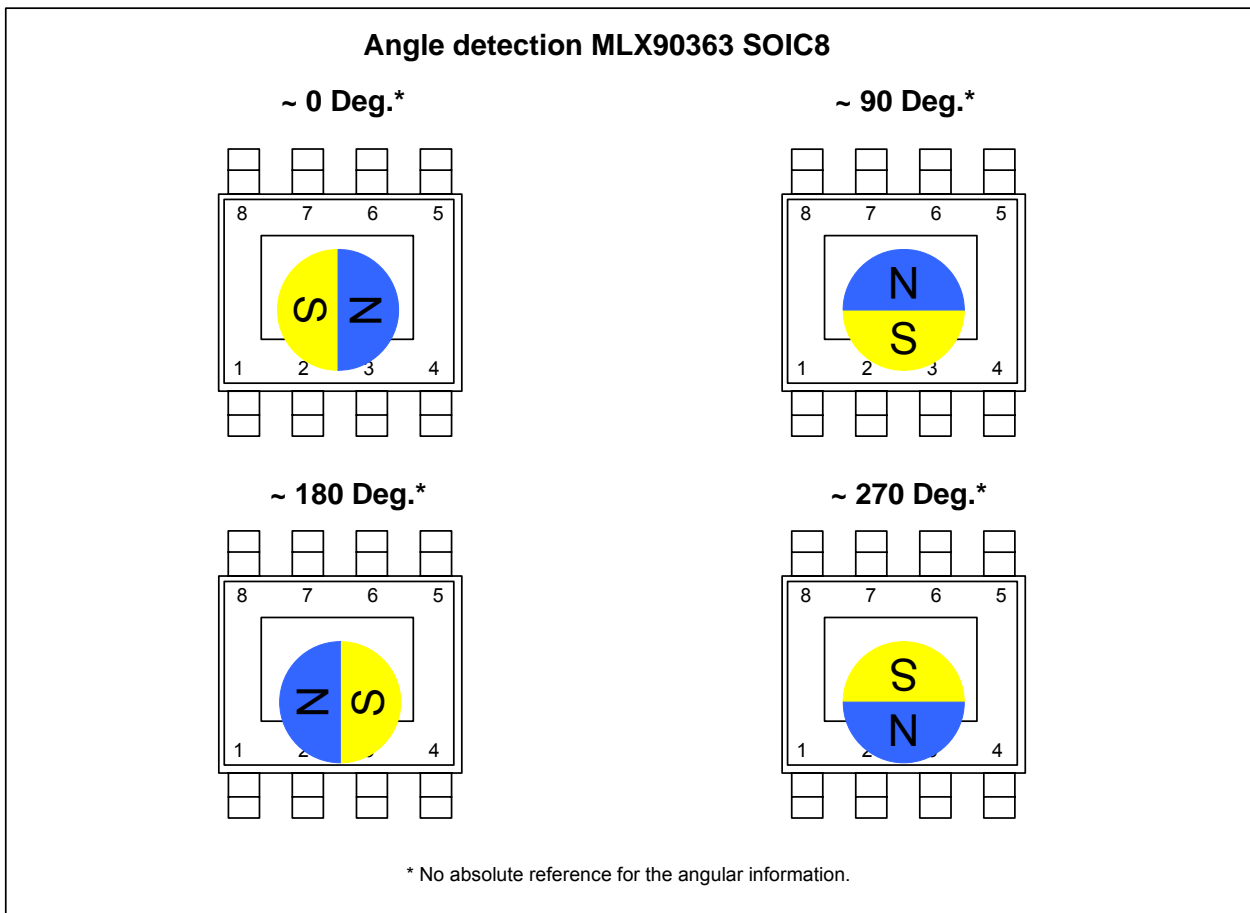
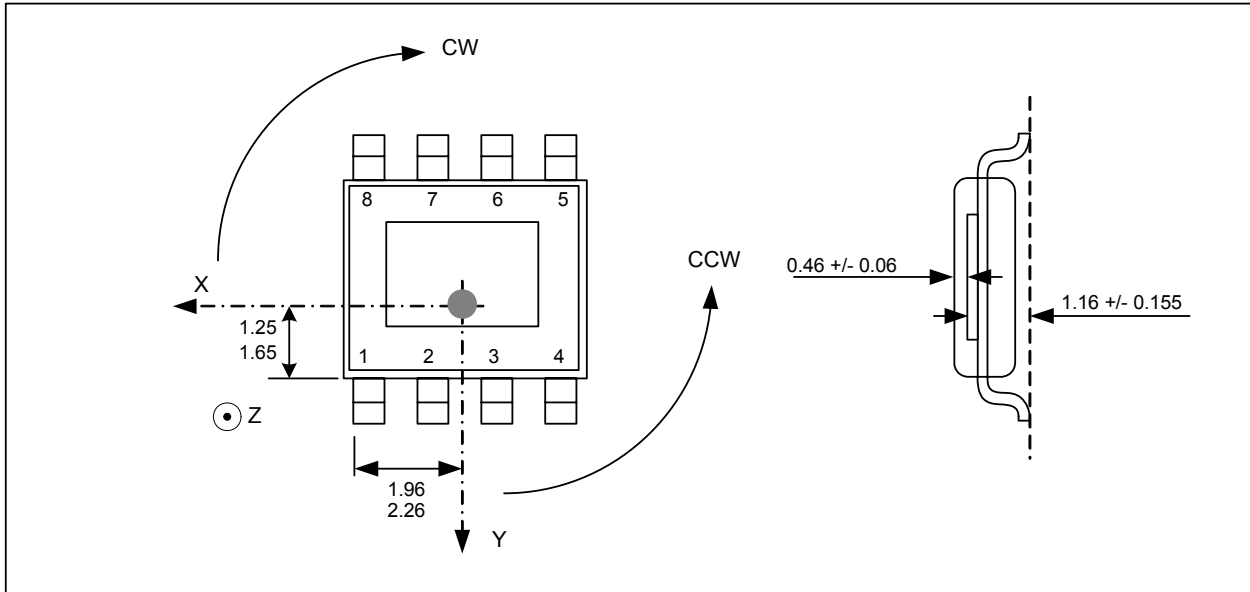

The MLX90363 is an absolute angular position sensor but the linearity error (Le – See Section 11) does not include the error linked to the absolute reference 0 Deg.

23.4. TSSOP16 – Package Dimensions

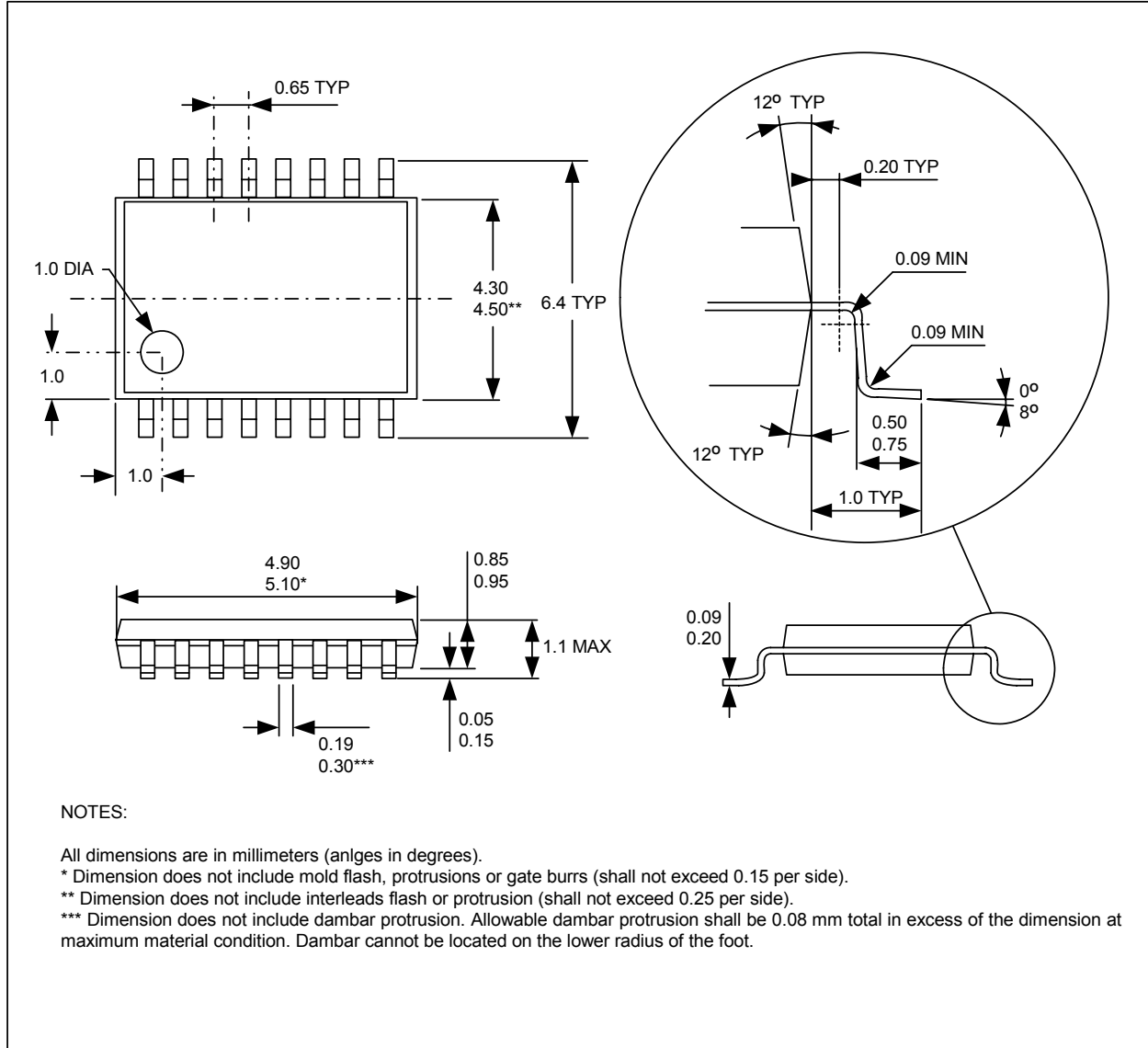

23.5. TSSOP16 – Pinout and Marking

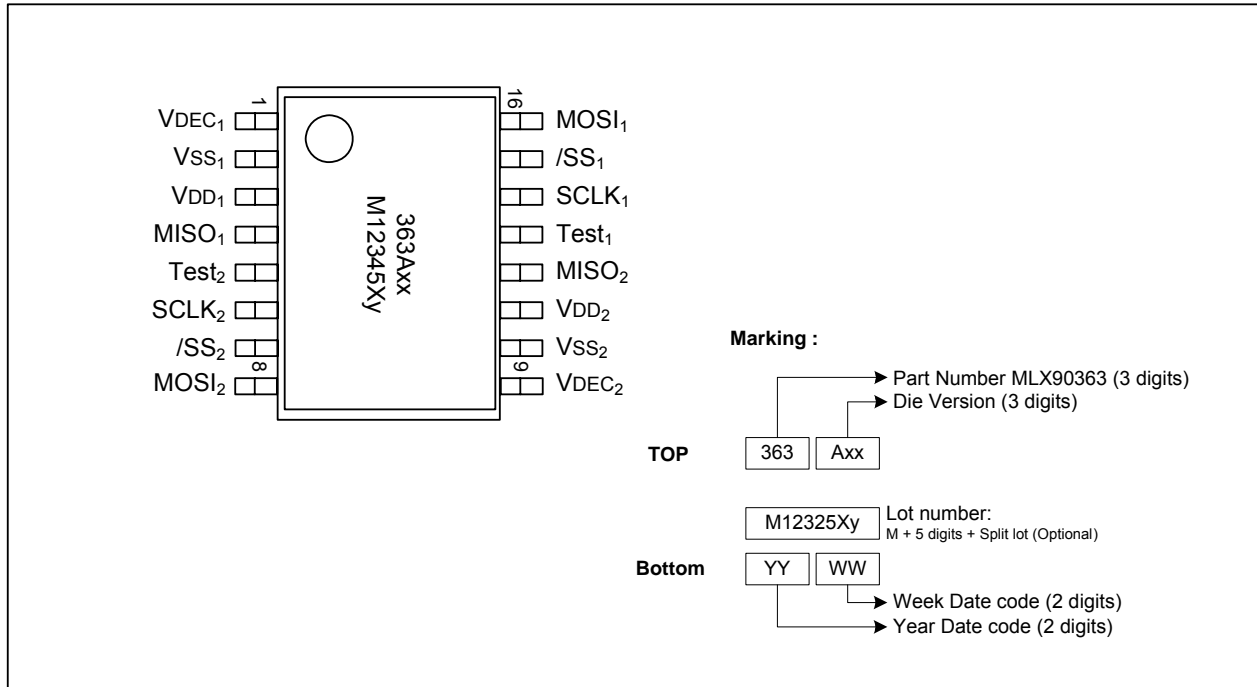

23.6. TSSOP16 – IMC Positioning

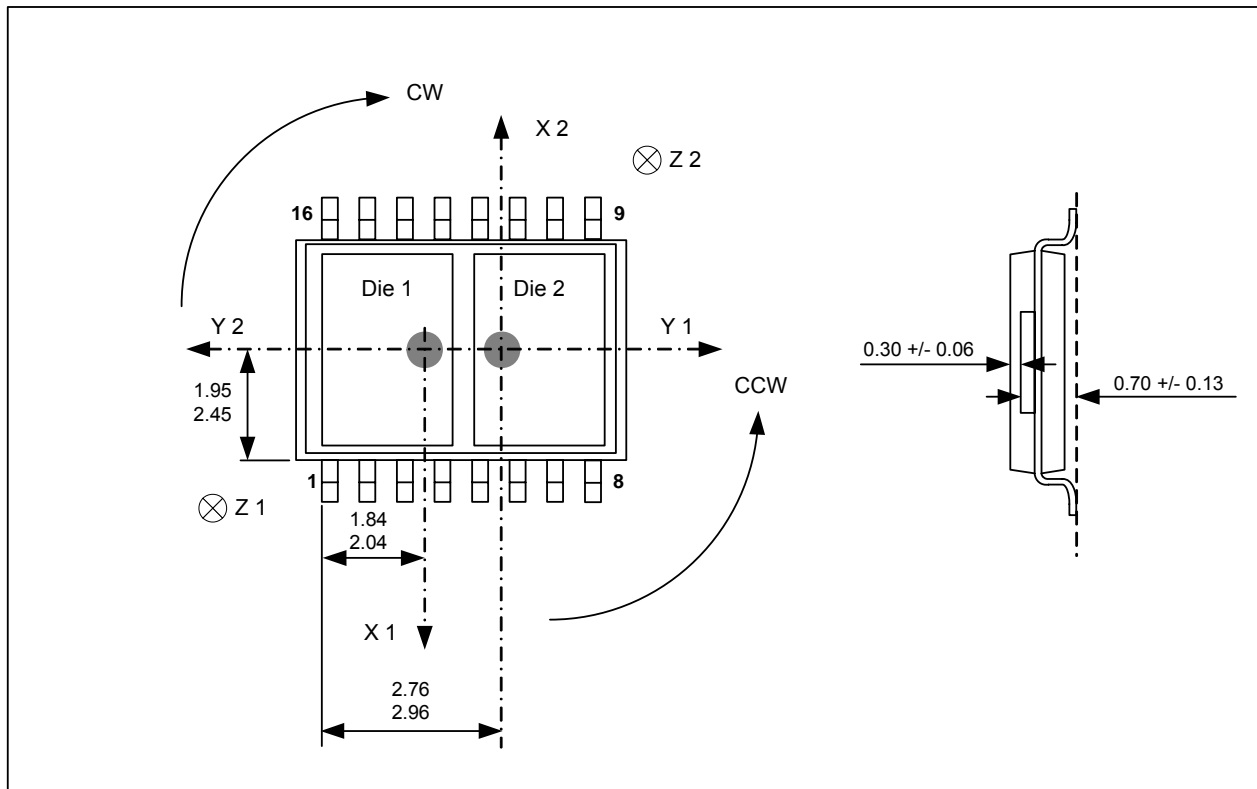

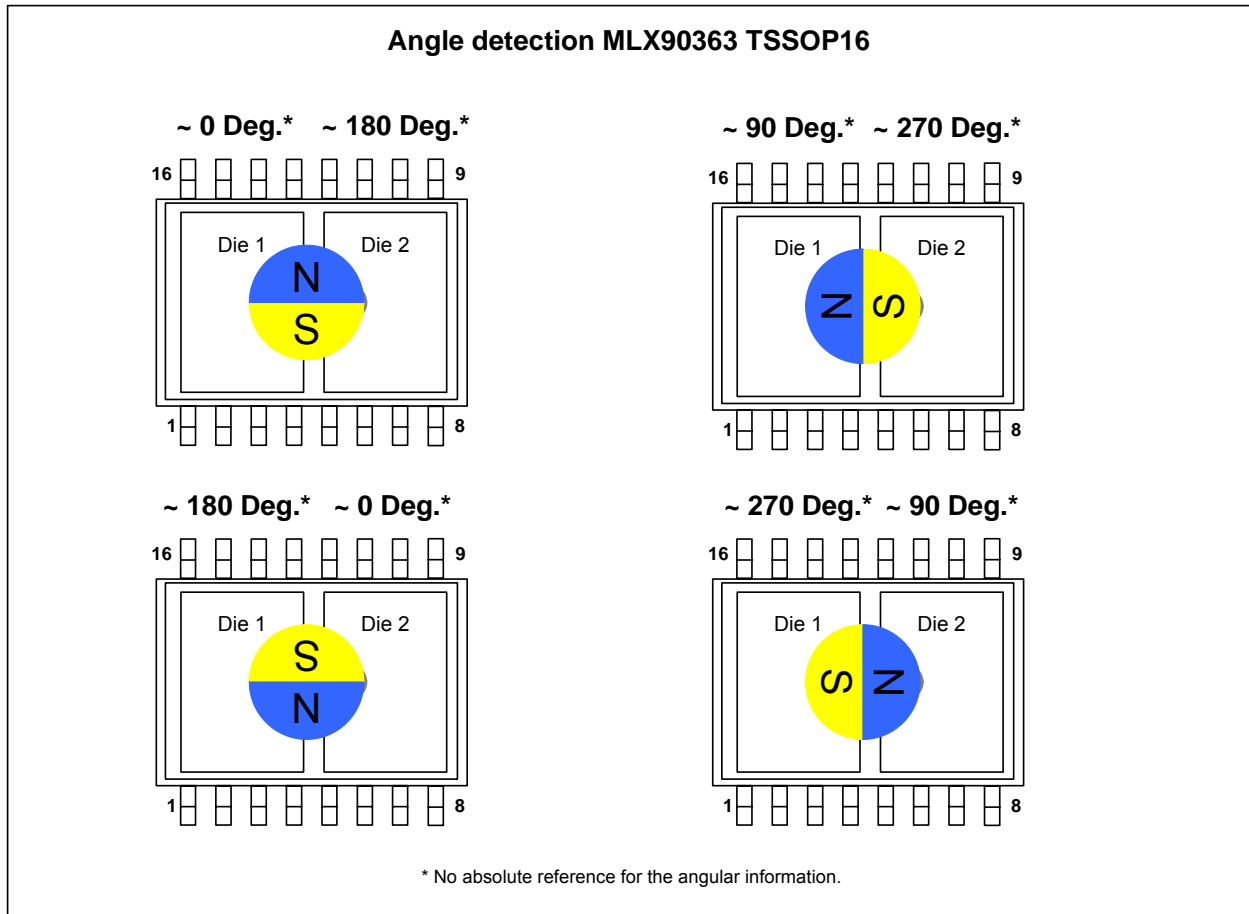

The MLX90363 is an absolute angular position sensor but the linearity error (Le – See Section 11) does not include the error linked to the absolute reference 0 Deg.

24. Disclaimer

Devices sold by Melexis are covered by the warranty and patent indemnification provisions appearing in its Term of Sale. Melexis makes no warranty, express, statutory, implied, or by description regarding the information set forth herein or regarding the freedom of the described devices from patent infringement. Melexis reserves the right to change specifications and prices at any time and without notice. Therefore, prior to designing this product into a system, it is necessary to check with Melexis for current information. This product is intended for use in normal commercial applications. Applications requiring extended temperature range, unusual environmental requirements, or high reliability applications, such as military, medical life-support or life-sustaining equipment are specifically not recommended without additional processing by Melexis for each application.

The information furnished by Melexis is believed to be correct and accurate. However, Melexis shall not be liable to recipient or any third party for any damages, including but not limited to personal injury, property damage, loss of profits, loss of use, interrupt of business or indirect, special incidental or consequential damages, of any kind, in connection with or arising out of the furnishing, performance or use of the technical data herein. No obligation or liability to recipient or any third party shall arise or flow out of Melexis' rendering of technical or other services.

© 2011 Melexis N.V. All rights reserved.

For the latest version of this document, go to our website at
www.melexis.com

Or for additional information contact Melexis Direct:

Europe, Africa, Asia:
Phone: +32 1367 0495
E-mail: sales_europe@melexis.com

America:
Phone: +1 603 223 2362
E-mail: sales_usa@melexis.com

ISO/TS 16949 and ISO14001 Certified