

急件       一般件

	<b>設計暨工程變更通知 (E C N)</b> <b>Engineering Change Notice</b>	ECN No. : RD-20090116-ECN-001
		Date : 2009/01/16
		SHT :

Customer : ALL	Type : RJ45 Connector Tab UP With LED	Effective date : 2009/01/16
Ref. : A1	Taimag P/N : RJL-XXXLC1_C2_B1_B2 & HS00-02001LF	

Material change  
 Procedure change  
 Circuit change  
 Dimension change  
 Other:

Deal with the way :

C : Cancel                      S : Scrap  
B : Return                      R : Re-work  
U : Unchange                  N/A : Unallied

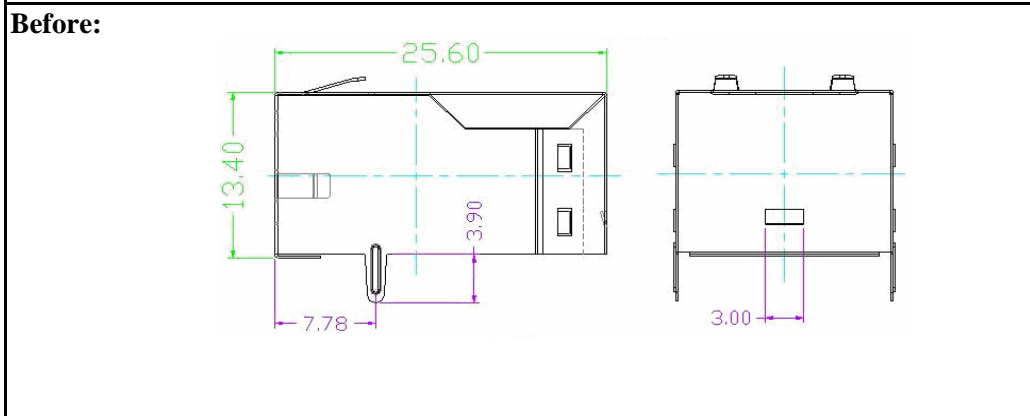

	C	B	U	S	R
PO					
Material not ready					
Semi-finished					
After passing IR					
After test					
Finished product					
Shipped product					
Re-work product					

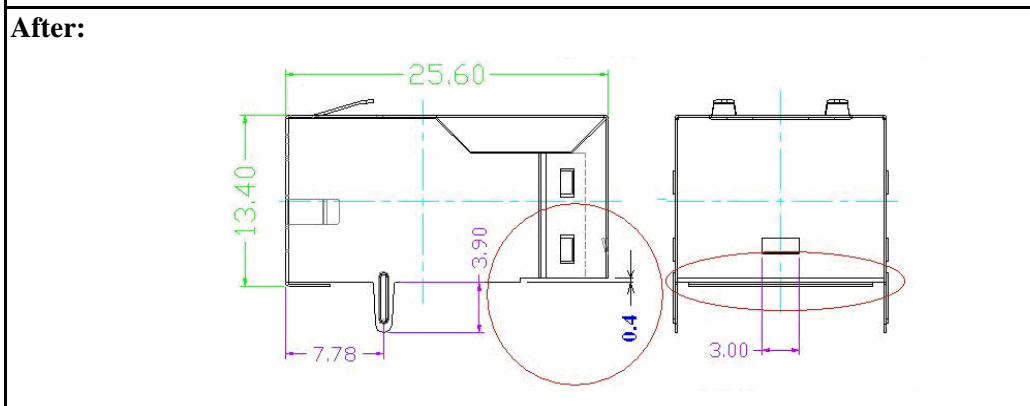

Changing document needed/Item :

Material (BOM)     SPEC      
 Supplier approving    Supplier drawing  
 IR PROFIL temp.

Description:

1.因歐盟2008年無鹵要求,需重新修機構材質,將Plastic Part 由原PBT材質改為LCP材質。  
As the halogen free compliance by the European Union from 2008, we have to change the material of plastic from PBT to LCP.  
2.為防止鐵殼與PCB上的Layout電路太接近,在鐵殼增加0.4mm逃邊。  
The Layout circuit of PCB is too close to the metal case, so we add a gap of 0.4mm by the metal case.

Others : The raw materials accord with ROHS

Cd 75ppm max     Hg 1000ppm max  
 Pb 1000ppm max    Cr6+ 1000ppm  
 Cl 900ppm max     PBDEs 1000ppm  
 Br 900ppm max     PBBs 1000ppm

Maker : 張桂芳	Issue to : <input checked="" type="checkbox"/> Producing Dept. <input checked="" type="checkbox"/> IQC <input checked="" type="checkbox"/> Engineering Dept. <input checked="" type="checkbox"/> QC Dept. <input checked="" type="checkbox"/> Resourcing Dept. <input checked="" type="checkbox"/> Purchasing Dept. <input checked="" type="checkbox"/> Technology Dept. <input checked="" type="checkbox"/> Marketing Dept. <input checked="" type="checkbox"/> Taimag R&D <input checked="" type="checkbox"/> Customer
Inspector : 曾军	
Approving : 謝善光	
(部門主管或指定代理人)	

After issue, please fill in for confirmation :

Confirmed : 謝善光

Confirm date : 16/1/2009

Closed :       No related :